



**SPREADERS**

July 15, 2018  
Lit. No. 72187, Rev. 00

# MECHANIC'S GUIDE

***STEEL*  *CASTER***<sup>TM</sup>

**STEEL HOPPER SPREADERS,**

**POLY  CASTER**<sup>TM</sup>

**POLY HOPPER SPREADERS,**

**LOW PROFILE &  *SPEED-CASTER***<sup>TM</sup>

**Tailgate Spreaders**

featuring the

***FLEETFLEX***  
ELECTRICAL SYSTEM

**⚠ CAUTION**

Read this manual before servicing the spreader.



# TABLE OF CONTENTS

---

<b>INTRODUCTION</b> .....	4	Troubleshooting Guide.....	26
Recommended Tools.....	4	Electrical System .....	28
<b>SAFETY</b> .....	5	Poly Hopper Harness/Cable Assemblies .....	28
<b>ELECTRICAL SYSTEM</b> .....	10	Wiring: Vehicle Harness Diagram.....	30
<b>HOPPER SPREADERS</b> .....	11	Harnessing Components.....	31
Specifications.....	11	Module Box Harness Routing Diagram .....	32
Theory of Operation.....	12	Spinner Motor Replacement .....	33
Operating the Spreader – Cab Controls .....	13	Gear Box.....	34
Powering the Control .....	13	Replacing the Gear Box Assembly: FLEET FLEX System.....	35
Cab Control Modes.....	13	Replacing the Conveyor Chain: FLEET FLEX System .....	36
Cab Control Codes .....	14	<b>STAINLESS STEEL HOPPER SPREADERS</b> .....	<b>37</b>
Setup Procedure.....	16	Testing .....	38
<b>POLY HOPPER SPREADERS</b> .....	17	Steel Hopper Spreader Harness Testing Procedure .....	38
Removing the Spreader .....	18	Checking Vehicle Control Harness .....	38
Storage .....	19	Checking Vehicle Spreader Harness .....	39
Maintenance .....	20	Checking Spreader Harness Assembly .....	40
Grease Fittings .....	20	Troubleshooting Guide.....	41
Conveyor Pintle Chain Tension.....	20	<b>Electric Models</b>	
After Each Use .....	20	Electrical System .....	43
Controlling Material Application .....	21	Wiring: Vehicle Harness Diagram.....	43
Testing .....	22	Stainless Steel Hopper Harness/Cable Assemblies.....	44
Poly Hopper Spreader Harness Testing Procedure .....	23	Harnessing Components .....	46
Checking Vehicle Control Harness .....	23		
Checking Vehicle Spreader Harness .....	24		
Checking Spreader Harness Assembly .....	25		

*Continued on next page*

# TABLE OF CONTENTS

---

*Continued from page 1*

## **Gas Models**

Relay Kit Installation Instructions.....	47
Cab Control Wiring Instructions: 11-Pin Harness.....	48
Electrical System:	
Briggs & Stratton w/Spreader Battery.....	50
Briggs & Stratton w/Vehicle Battery.....	51
Honda w/Spreader Battery.....	52
Honda w/Vehicle Battery.....	53

## **Electric Models**

Troubleshooting Guide: Electric Clutch.....	54
Removing & Installing – Gas – Electric Clutch.....	55
Spinner Motor Replacement.....	57
Replacing the Gear Box.....	58

## **Gas & Hydraulic Models**

Replacing the Gear Box.....	59
Servicing the Gear Box.....	60

## **Gas, Electric & Hydraulic Models**

Replacing the Conveyor Chain: FLEET FLEX System.....	61
Conveyor Pintle Chain Tension.....	62

## **Chute Adjustment**

Gas Models	
Chute Length Adjustment.....	63
Chute Installation.....	65

## Hydraulic Models

Chute Length Adjustment.....	67
Chute Installation.....	69

## Electric Models

Chute Length Adjustment.....	70
------------------------------	----

## **SPREADER ACCESSORIES.....71**

### **Strobe Light.....72**

### **Pre-Wet Kit.....73**

#### Full-Feature Control

Harness Wiring Diagram.....	73
Harness Wiring Diagram (Full-Feature System).....	74
Troubleshooting Guide.....	75

#### On/Off Control

Harness Wiring Diagram.....	76
Troubleshooting Guide.....	77

#### On/Off Legacy System (Poly II Hopper Spreaders)

Harness Wiring Diagram: ON/OFF.....	78
Harness Wiring Diagram: Pre-Wet Relay Harness.....	79

#### Maintenance..... 80

#### Periodic Maintenance..... 80

#### Cleaning..... 80

#### End of Season and Storage..... 80

#### Electrical Schematics.....81

*Continued on next page*



---

Continued from page 2

<b>TAILGATE SPREADERS</b> .....	<b>82</b>	<b>SPEED-CASTER™ Tailgate Spreaders</b> .....	<b>92</b>
Electrical System .....	83	Harness Testing .....	93
Operating the Spreader – Cab Control .....	84	Checking Vehicle Control Harness .....	93
Controlling Material Application .....	84	Tailgate Harness/Cable .....	94
Cab Control Modes .....	84	Checking Spreader Harness Assembly .....	96
Cab Control Codes .....	85	<b>LOW-PROFILE Tailgate Spreaders</b> .....	<b>97</b>
Cab Control Troubleshooting .....	85	Wireless Control Programming and Pairing .....	98
Setup Procedures .....	87	Programming and Pairing the Wireless Key Fob Control .....	99
Auto-Reverse ( <b>Ar</b> ) Feature .....	88	Wireless Compliance .....	100
Vibrator Function .....	88	Electrical Diagram – Wireless Receiver Module Connections .....	101
Controlling Flow of Material .....	88	7-Pin, 7-Way Accessory Harness, 216" .....	102
Troubleshooting Guide .....	89	Troubleshooting .....	103
Harness Wiring Diagram .....	91		

# INTRODUCTION

---

This guide has been prepared to assist the trained mechanic in the service of FISHER® hopper and tailgate spreaders. It also provides safety information and recommendations. We urge all mechanics to read this manual carefully before attempting to service the FISHER spreader equipment covered by this guide.

Service of your FISHER spreader equipment is best performed by your local FISHER products outlet. They know your spreader best and are interested in your complete satisfaction.

## RECOMMENDED TOOLS

- Long/slender needle-nose pliers
- Screwdriver set
- 12V test light
- Torque wrench
- Allen wrench set
- Combination standard wrench set
- 1/4" drive ratchet set with 6" extension
- 3/8" drive ratchet set
- Multimeter
- Ampere clamp
- 10-pin test harness
- Flashlight
- Pick set
- Hammer
- Automotive-style fuses
- Spare fuses:
  - 100A – main for electric
  - 25A – ATC vibrator
  - 15A – ATC/ATO pre-wet
  - 4A – ATC strobe light
  - 4A – ATC work light

# SAFETY

## SAFETY DEFINITIONS

### ⚠ WARNING

Indicates a potentially hazardous situation that, if not avoided, could result in death or serious personal injury.

### ⚠ CAUTION

Indicates a potentially hazardous situation that, if not avoided, may result in minor or moderate injury. It may also be used to alert against unsafe practices.

**NOTE:** Indicates a situation or action that can lead to damage to your spreader and vehicle or other property. Other useful information can also be described.

### Warning Label – Gasoline

#### ⚠ WARNING

Gasoline is flammable.

- Turn off engine and allow it to cool before filling gas tank.
- DO NOT smoke or use open flame within 25 feet of spreader.
- Allow spilled gas to evaporate completely before starting engine.
- Gasoline engine produces poisonous gases while running. DO NOT operate in an enclosed area.
- Gasoline engine has hot and moving parts that can cause injury. Use care when working with or near the gasoline engine and its parts.
- Shut off engine when not in use, even for short periods of time, to avoid damage to equipment or property.

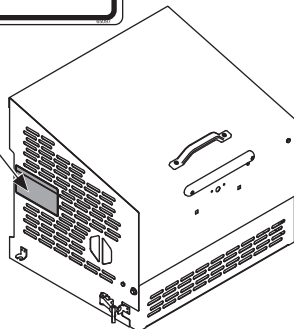

## WARNING/CAUTION AND INSTRUCTION LABELS

Become familiar with and inform users about the warning and instruction labels on the spreader.

**NOTE:** If labels are missing or cannot be read, see your sales outlet.

### Warning Label – Rear Camera

#### ⚠ WARNING

Vehicles <10,000 lb GVWR

Obstructing the visibility from the vehicle's rear camera could result in serious injury or damage. An auxiliary camera system shall be installed if the vehicle's rear camera is removed or blocked.

### Caution Label – Lifting

#### ⚠ CAUTION

Do not lift spreader by this member. Lifting here could cause personal injury and property damage.

67272

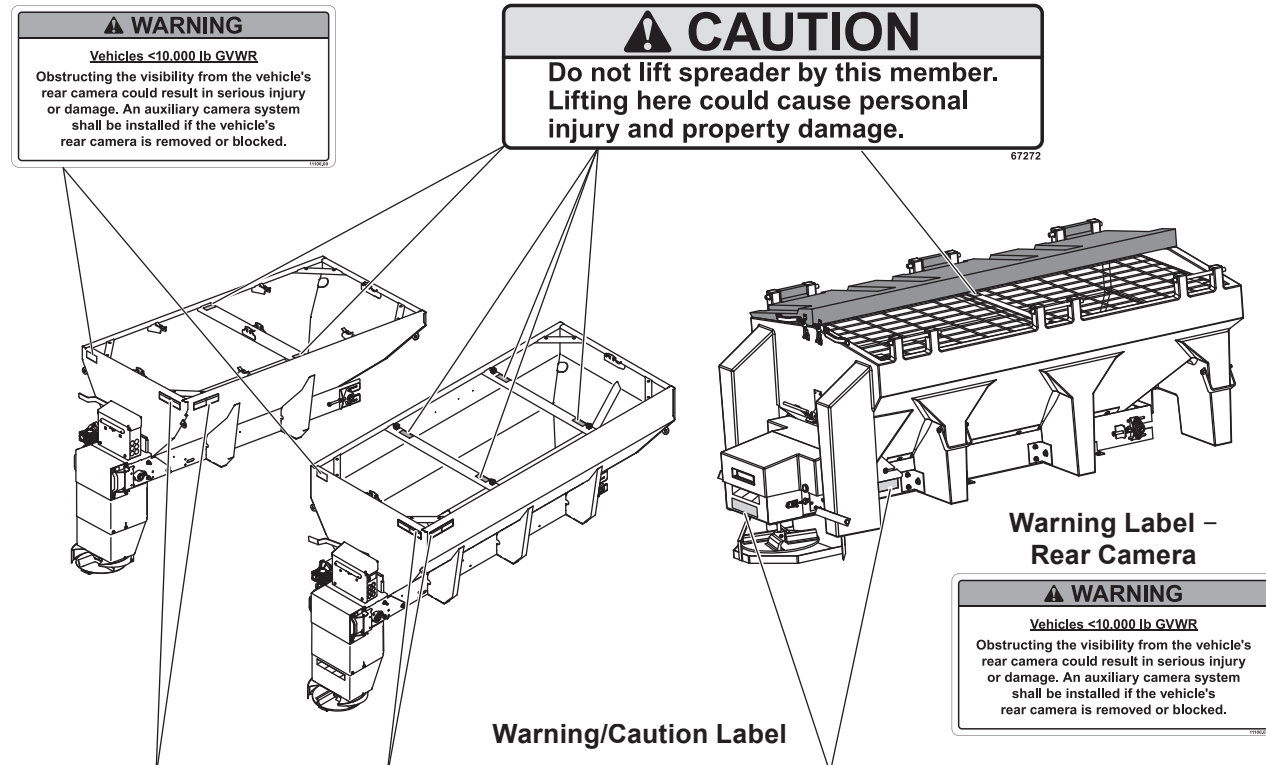

### Warning Label – Rear Camera

#### ⚠ WARNING

Vehicles <10,000 lb GVWR

Obstructing the visibility from the vehicle's rear camera could result in serious injury or damage. An auxiliary camera system shall be installed if the vehicle's rear camera is removed or blocked.

### Warning/Caution Label



#### ⚠ WARNING

- DO NOT exceed GVWR or GAWR with spreader and load.
- Turn spreader OFF before filling, adjusting or cleaning.
- Bystanders to stay a minimum of 25 feet away from operating spreader.
- DO NOT climb into or ride on spreader.
- Keep hands, feet and clothing away from moving conveyor and spinner.



#### ⚠ CAUTION

- Read Owner's Manual before operating or servicing spreader.
- Empty and clean spreader after every use.

66584

# SAFETY

## WARNING/CAUTION AND INSTRUCTION LABELS

Become familiar with and inform users about the warning and instruction labels on the spreader.

**NOTE: If labels are missing or cannot be read, see your sales outlet.**

Spreaders with swing mount option only.

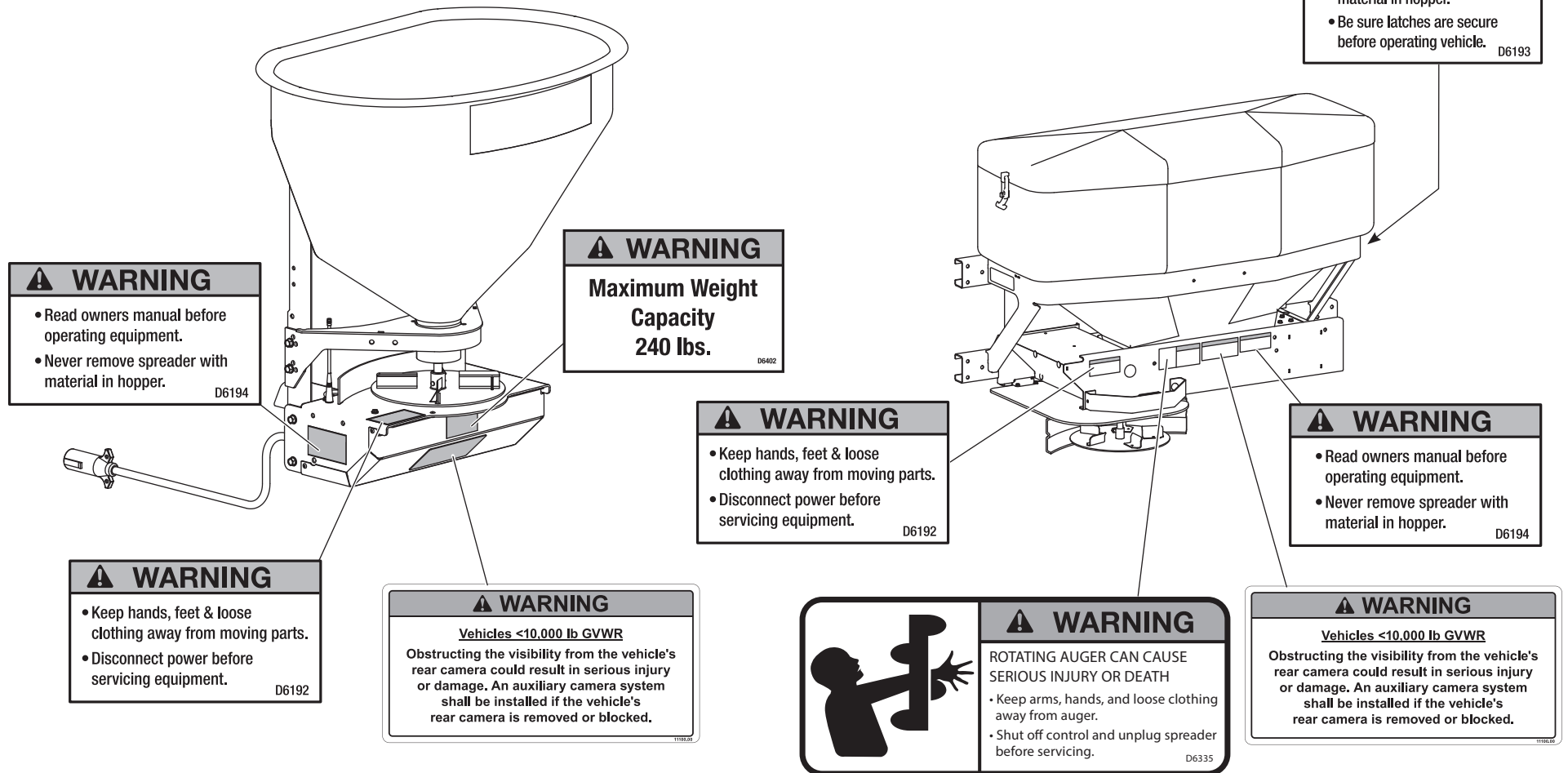

# SAFETY

## SAFETY PRECAUTIONS

Improper installation and operation could cause personal injury, and/or equipment and property damage. Read and understand labels and the Owner's Manual before installing, operating, or making adjustments.

### ⚠ WARNING

- Driver to keep bystanders minimum of 25 feet away from operating spreader.
- Before working with the spreader, secure all loose-fitting clothing and unrestrained hair.
- Before operating the spreader, verify that all safety guards are in place.
- Before servicing the spreader, wait for conveyor, auger, and spinner to stop.
- Do not climb into or ride on spreader.

### ⚠ WARNING



Overloading could result in an accident or damage. Do not exceed GVWR or GAWR ratings as found on the driver-side vehicle door cornerpost. See Loading section of Owner's Manual to determine maximum volumes of spreading material.

### ⚠ WARNING

Do not install the control for this product in the deployment path of an air bag. Refer to vehicle manufacturer's manual for air bag deployment area(s).

### ⚠ WARNING

Vehicles  $\leq 10,000$  lb GVWR: Obstructing the visibility from the vehicle's rear camera could result in serious injury or damage. An auxiliary camera system shall be installed if the vehicle's rear camera is removed or blocked.

### ⚠ WARNING

With chute removed, use dump switches to operate conveyor.

### ⚠ CAUTION

If rear directional, CHMSL light, or brake stoplights are obstructed by the spreader, the lights shall be relocated, or auxiliary directional or brake stoplights shall be installed.

### ⚠ CAUTION

During the hopper installation we recommend the addition of an OSHA compliant Backup Alarm. This alarm is required for OSHA governed employers.

### ⚠ CAUTION

- Do not operate a spreader in need of maintenance.
- Before operating the spreader, reassemble any parts or hardware removed for cleaning or adjusting.
- Before operating the spreader, remove materials such as cleaning rags, brushes, and hand tools from the spreader.
- Before operating the spreader, read the engine owner's manual, if so equipped.
- While operating the spreader, use auxiliary warning lights, except when prohibited by law.
- Tighten all fasteners according to the torque chart. Refer to torque chart for the recommended torque values.
- When pressure washing motor enclosure area, keep spray at least 36" away from motor enclosures.

### ⚠ WARNING



Hydraulic fluid under pressure can cause skin injection injury. If you are injured by hydraulic fluid, get medical attention immediately.

## HYDRAULIC SAFETY

- Always inspect hydraulic components and hoses before using. Replace any damaged or worn parts immediately.
- If you suspect a hose leak, DO NOT use your hand to locate it. Use a piece of cardboard or wood.

# SAFETY

## CAUTION

Disconnect electric and/or hydraulic power and tag out if required before servicing or performing maintenance.

## CAUTION



DO NOT leave unused material in hopper. Material can freeze or solidify, causing unit to not work properly. Empty and clean after each use.

**NOTE:** Lubricate grease fittings after each use. Use a good quality multipurpose grease.

**NOTE:** Pay special attention when drilling or clamping dissimilar metals to aluminum bodies. Galvanic corrosion can occur if not handled properly. Contact vehicle manufacturer for recommended attachment practices.

## FUSES

The FISHER® electrical and hydraulic systems contain several automotive-style fuses. If a problem should occur and fuse replacement is necessary, the replacement fuse must be of the same type and amperage rating as the original. Installing a fuse with a higher rating can damage the system and could start a fire. Fuse Replacement, including fuse ratings and locations, is located in the Maintenance section of the Owner's Manual.

## PERSONAL SAFETY

- Remove ignition key and put the vehicle in PARK or in gear to prevent others from starting the vehicle during installation or service.
- Wear only snug-fitting clothing while working on your vehicle or spreader.
- Do not wear jewelry or a necktie, and secure long hair.
- Wear safety goggles to protect your eyes from battery acid, gasoline, dirt, and dust.
- Avoid touching hot surfaces such as the engine, radiator, hoses, and exhaust pipes.
- Always have a fire extinguisher rated BC handy, for flammable liquids and electrical fires.

## FIRE AND EXPLOSION

### WARNING

Gasoline is highly flammable and gasoline vapor is explosive. Never smoke while working on vehicle. Keep all open flames away from gasoline tank and lines. Wipe up any spilled gasoline immediately.

Be careful when using gasoline. Do not use gasoline to clean parts. Store only in approved containers away from sources of heat or flame.

## CELL PHONES

A driver's first responsibility is the safe operation of the vehicle. The most important thing you can do to prevent a crash is to avoid distractions and pay attention to the road. Wait until it is safe to operate Mobile Communication Equipment such as cell phones, text messaging devices, pagers, or two-way radios.

## VENTILATION

### WARNING

Vehicle exhaust contains lethal fumes. Breathing these fumes, even in low concentrations, can cause death. Never operate a vehicle in an enclosed area without venting exhaust to the outside.

# SAFETY

## BATTERY SAFETY

### ⚠ CAUTION

Batteries normally produce explosive gases, which can cause personal injury. Therefore, do not allow flames, sparks, or lit tobacco to come near the battery. When charging or working near a battery, always cover your face and protect your eyes, and also provide ventilation.

- Batteries contain sulfuric acid, which burns skin, eyes, and clothing.
- Disconnect the battery before removing or replacing any electrical components.

## NOISE

Airborne noise emission during use is below 70 dB(A) for the spreader operator.

## VIBRATION

Operating spreader vibration does not exceed 2.5 m/s<sup>2</sup> to the hand-arm or 0.5 m/s<sup>2</sup> to the whole body.

## REAR VISION SYSTEMS

### ⚠ WARNING

Vehicles ≤10,000 lb GVWR: Obstructing the visibility from the vehicle's rear camera could result in serious injury or damage. An auxiliary camera system shall be installed if the vehicle's rear camera is removed or blocked.

The National Highway Traffic Safety Administration (NHTSA) has set new rear vision system requirements for vehicles with a 10,000 lb or lower Gross Vehicle Weight Rating (GVWR) in an update to the Federal Motor Vehicle Safety Standard (FMVSS) No. 111. It requires that vehicles with a rear vision system still have unobstructed use of that system (or an equivalent replacement) after the vehicle is altered. NHTSA offers information on this standard and testing procedures to verify auxiliary systems meet the standard on its website. It is the responsibility of the installer to verify that the vehicle complies with FMVSS.

## TORQUE CHART

### ⚠ CAUTION

Read instructions before assembling. Fasteners should be finger tight until instructed to tighten according to torque chart. Use standard methods and practices when attaching spreader, including proper personal protective safety equipment.

Recommended Fastener Torque Chart					
Inch Fasteners Grade 5 and Grade 8					
Size	Torque (ft-lb)		Size	Torque (ft-lb)	
	Grade 5	Grade 8		Grade 5	Grade 8
1/4-20	8.4	11.9	9/16-12	109	154
1/4-28	9.7	13.7	9/16-18	121	171
5/16-18	17.4	24.6	5/8-11	150	212
5/16-24	19.2	27.3	5/8-18	170	240
3/8-16	30.8	43.6	3/4-10	269	376
3/8-24	35.0	49.4	3/4-16	297	420
7/16-14	49.4	69.8	7/8-9	429	606
7/16-20	55.2	77.9	7/8-14	474	669
1/2-13	75.3	106.4	1-8	644	909
1/2-20	85.0	120.0	1-12	704	995
Metric Fasteners Class 8.8 and 10.9					
Size	Torque (ft-lb)		Size	Torque (ft-lb)	
	Class 8.8	Class 10.9		Class 8.8	Class 10.9
M6 x 1.00	7.7	11.1	M20 x 2.50	325	450
M8 x 1.25	19.5	26.9	M22 x 2.50	428	613
M10 x 1.50	38.5	53.3	M24 x 3.00	562	778
M12 x 1.75	67	93	M27 x 3.00	796	1139
M14 x 2.00	107	148	M30 x 3.50	1117	1545
M16 x 2.00	167	231	M33 x 3.50	1468	2101
M18 x 2.50	222	318	M36 x 4.00	1952	2701
These torque values apply to fasteners except those noted in the instructions.					

## ELECTRICAL SYSTEM

---

Amperage Draw (Approximate)		
Model/Components	Hopper Empty	Hopper Full of Sand
Hopper Spreaders		
Conveyor Motor	10–18A	30–45A
Spinner Motor	5–10A	10–15A
Switch Accessory Lead Draw	0.75A	0.75A
SPEED-CASTER™ Tailgate Spreaders		
Spinner	3–5A	8–10A
Auger Motor	7–9A	–
Vibrator	–	14–18A
Module Current* (Vibrator ON)	4–14A	10–33A
Spinner, Auger, Vibrator	13–17A	30–35A
LOW-PROFILE Wireless Tailgate Spreaders	3.5A	10A

\* Reading at the BAT/GND of the module.



# HOPPER SPREADERS: SPECIFICATIONS

---

## Gear Box

**NOTE: The blue gear box is lubricated for life and does not require oil changes.**

DO NOT attempt to drain gear oil.

## Hydraulic Fluid

**⚠ CAUTION**

**Do not mix different types of hydraulic fluid. Some fluids are not compatible and may cause performance problems and product damage.**

## Gas & Hydraulic: Oil Specification

- Mobil SHC 632, Exxon SHP 320, or equivalent synthetic gear oil SAE grade 80W90 synthetic

## Electrical System (Approximate)

- Conveyor Motor = 10–18A empty  
= 30–45A loaded
- Spinner Motor = 5–10A empty  
= 10–15A loaded
- Switch Accessory Lead Draw = 0.75A

## Fastener Torque Specifications

Motor Terminals (+ and –)	5/16"-18 Nut	50–60 in-lb
Motor Relay Small Terminals	10"-32 Nut	15 in-lb max.
Motor Relay Large Terminals	5/16"-24 Nut	35 in-lb max.
Spreader Module Mount Screws	1/4"-20 x 5/8"	60–70 in-lb

# HOPPER SPREADERS: THEORY OF OPERATION

---

## STEEL / POLY HOPPER SPREADERS (ELECTRIC MODELS)

The spreader is controlled by a FLEET FLEX multiplex electrical system. Using a digital signal, the control sends inputs to the spreader module which controls the conveyor and spinner speed independently. The module, in turn, monitors amperage draw and will display any fault codes on the control display screen.

Examples:

(EH) Empty Hopper,

(CE) Communication Error.

The control also gives the operator the ability to adjust the brightness level of the LED lights, and to calibrate the empty hopper setting.

---

**NOTE: Calibrating the empty hopper setting should be part of the set-up procedure, and must be calibrated when the spreader is empty. Failure to do so will result in a false code or no code when the spreader has run out of material.**

---

Digital signals are sent from the control, passing through the two communication wires in the vehicle control harness to the vehicle harness assembly (power cable with two communication lines), which also provides 12V DC and ground to the spreader. From there, it travels down the vehicle harness to the hopper harness assembly into the spreader module. Not only are the spreader conveyor and spinner speeds set, but so are accessories, such as vibrator, work lights, strobe lights, and the ON/OFF control of pre-wet systems.

The **vehicle control harness** also contains the red switched accessory wire and the orange Center High Mounted Stop Light (CHMSL) wire.

---

**NOTE: Not all vehicles will connect the CHMSL wire in the cab. Some may need to be connected at the rear of the vehicle. Check the body builder's guide pertaining to the make of the vehicle.**

---

The vehicle harness contains wiring for the license plate light and CHMSL light.

---

**NOTE: Not all vehicles will connect at the rear of the vehicle. Some may need to be connected in the cab. Check the body builder's guide pertaining to the make of the vehicle.**

---

12

See the Owner's Manual and Installation Instructions for more complete information.

# OPERATING THE SPREADER – CAB CONTROLS

---

## POWERING THE CONTROL

Power is not applied to the control until the vehicle ignition is turned to ACC or ON. Once the control has power it performs a light check and displays the software version on the status display. The control then checks for a connected spreader. If no spreader is detected, the following occurs:

- **nC** (no connection) appears on the red status display for five seconds;
- a single beep sounds;
- control enters Standby mode with no lights illuminated.

## CAB CONTROL MODES

### Ready Mode

Vehicle ignition is set to ACC or ON; cab control is OFF. Control has power.

The Material Width and Material Flow control knobs can be set to start-up conditions, but the spinner and hopper drives will not operate until the cab control is turned ON.

Accessory lights and vibrator (if installed) are operational. The BLAST function is not operational.

### ON Mode

Vehicle ignition is set to ACC or ON; cab control is ON.

Spinner and hopper motors will start. All cab control functions are operational. Accessory lights and vibrator (if installed) are operational.

During normal spreader operation, **no control codes are displayed**. Information or setup codes will appear when relevant. These codes will not stop spreader operation.

### Error Mode

When an error condition occurs, spreader operation will shut down. A two-digit error code will flash on the display and a beep will sound. If there are multiple error codes, the codes will flash in a repeating sequence.

Refer to the Error Codes portion of the following Cab Control Codes table. Also see the Troubleshooting Guide section of the Owner's Manual.

Once the error condition has been resolved, press the ON/OFF button to clear the error code(s). Press the ON/OFF button again to resume spreader operation.

The error code will reappear if the error condition has not been rectified. If the error condition persists, contact your authorized dealer.

Multiple resets within a short time frame will cause the hopper module to time out if components are overheating. The control will display an **EF** error code.

Accessory work lights and strobe lights can be used when an error code is in effect and will remain in their current state. The vibrator and pre-wet will not function.

# OPERATING THE SPREADER – CAB CONTROLS

## CAB CONTROL CODES

Setup Codes		
Code	Definition	Procedure
<b>Cb</b>	Calibrate the Empty Hopper setting.	With control in ON mode, press and hold the left control knob until the <b>Cb</b> code displays. Calibration cycle is automatic.*
<b>Cc</b>	Clear calibration data for Empty Hopper setting; clear <b>EH</b> code.	Press the right control knob to clear all calibration data during the calibration cycle.
<b>LS</b>	Set LED brightness level.	With control in Ready mode, press and hold left control knob to get <b>LS</b> code. Release pressure and turn left control knob to desired brightness setting. Wait for confirming <b>SL</b> code to display.*
<b>SL</b>	Confirms that LED brightness level has been reset.	

\* For full instructions, see the Setup Procedures section of the Owner's Manual.

Information Codes		
Code	Definition	Response
<b>dU</b>	Spreader is in dump mode: <ul style="list-style-type: none"> <li>• Material chute is open.</li> <li>• Back Dump buttons are enabled.</li> </ul>	To operate the dump function, see instructions in the Operating the Spreader section of this manual. If <b>dU</b> code displays when the material chute is closed and latched, contact authorized dealer.
<b>EH</b>	Empty hopper (beep will sound).	Check hopper for material. Recalibrate Empty Hopper setting as described above for <b>Cb</b> code.
<b>Lb</b>	Low battery. Hopper module is sensing <10V. ( <b>Lb</b> becomes an error code when module senses ≤ 6V.)	Refer to the <b>Lb</b> row under "Error Codes" (see table below).

14

Error Codes – Spreader Operation Stopped			
Code	Definition	Possible Cause	Suggested Solution
<b>bb</b>	Bad button.	Button is stuck. Button was pressed while vehicle ignition was entering ACC or START mode.	Inspect control. Free up button. Do not press any spreader cab control buttons while the vehicle ignition is being engaged.
<b>bH</b>	Bad hopper.	Possible module or control mismatch.	Replace control or module. Use only genuine service parts. Contact authorized dealer.
<b>CE</b>	No communication with spreader module.	Loose connection. Module lost power.	Confirm that spreader and control harnesses are connected to the vehicle harness. Check power to spreader module, all connections, fuses, and power studs. Check that port B is plugged in. Unplug the control at the end of the season or when the spreader is removed from the vehicle.
<b>CP</b>	Chute present fault.	Chute is open. Bad connection at chute position mag switch. (Can occur when driving on rough surface.)	Close the chute. Reset the control by pressing the ON/OFF button. If <b>CP</b> code continues to display, contact authorized dealer.
<b>Ct</b>	Control is hot.	Cab temperature is too high. Control overheated.	Turn off spreader and allow control to cool off.

Table continues on next page.

## OPERATING THE SPREADER – CAB CONTROL

Cab Control Codes, continued

Error Codes – Spreader Operation Stopped			
Code	Definition	Possible Cause	Suggested Solution
<b>EF</b>	Excessive drive faults.	Too many <b>HO</b> and/or <b>SO</b> error codes; hopper module overheating.	Control times out for 60 seconds. Ensure that conveyor and/or spinner are not jammed.
<b>HO</b>	Hopper overload – software trip.	Drive system has high current.	Inspect conveyor; clear material jam, or fix chain as needed.
<b>HO.</b>	Hopper overload – hardware trip.	Material is jammed. Chain is damaged.	
<b>HP</b>	Hopper power issue. No motor present.	Hopper drive motor is not connected. Possible motor defect.	Check connections to the conveyor drive motor (P—FEED and GND posts on the module and studs on the motor). Replace the motor.
<b>Lb</b>	Low battery. Hopper module is sensing $\leq 6V$ .	Bad connection or low battery. Snowplow or other vehicle power use may be driving down voltage.	Voltage is measured at the hopper module, so <b>Lb</b> code may indicate cable voltage loss. Check battery, alternator, and connections.
<b>OH</b>	Overheating.	Spreader module is too hot.	Allow a cool-off period of 60 seconds or longer. Check for loose harness connections. Check accessory connections. Check integrity of accessory wiring and harness. Clear jammed material. Contact authorized dealer.
<b>OH.</b>	Overheating module – microprocessor.	Spreader module malfunction. Accessories wiring/function problem. Drive motor overload.	
<b>rS</b>	Reset of spreader module.	Power loss to module detected on startup.	Reset the control by pressing the ON/OFF button. Check vehicle harness and battery connections.
<b>SO</b>	Spinner drive overload – software trip.	Material jammed in chute. Spinner shaft is damaged.	Inspect spinner and spinner drive components for alignment and condition. Check for damage to bearings, belts, shafts, and sprockets. Adjust and replace parts as required.
<b>SO.</b>	Spinner drive overload – hardware trip.	Drive belt is misaligned.	
<b>SP</b>	Spinner power issue. No motor present.	Spinner drive motor is not connected. Possible motor defect.	Check connections to the motor (SPIN and GND posts on the module). Replace the motor.

15

Excerpts taken from STEEL-CASTER™ Stainless Steel Hopper Spreader Owner's Manual (Lit. No. 99590, Rev. 02).

# OPERATING THE SPREADER – CAB CONTROL

---

## CAB CONTROL – SETUP PROCEDURES

### Calibrate the Empty Hopper Setting (Cb and EH Codes)

Calibrating the empty hopper setting enables the cab control to alert the operator when the hopper is empty.

Recalibrate the empty hopper setting at the start of each ice-control season.

1. Ensure that the hopper is empty before beginning the calibration.
2. Turn the vehicle ignition to ACC or ON. Press the ON/OFF button on the cab control to turn the control ON.
3. Press and hold the Material Width (left) knob for approximately 10 seconds until the **Cb** code displays.
4. The calibration cycle will begin. The blue LEDs around the Material Flow (right) knob will illuminate in succession until all eight are lit.
5. When the automatic calibration cycle is complete, the control will automatically revert to the previous material application settings.

If the control is turned OFF or loses power during the calibration cycle, the calibration data will be lost. Make sure the control is ON and restart the calibration process at Step 3.

Once the empty hopper setting has been calibrated, the **EH** code will flash on the display and a beep will sound whenever the hopper is empty. The **EH** code is informational only and will not stop spreader operation.

### Clearing Empty Hopper Calibration Data (Cc Code)

The empty hopper calibration may be cleared, if desired. The control will no longer display the **EH** status code when the hopper is empty.

Start the calibration cycle as described above. At Step 4, press the Material Flow (right) knob during the calibration cycle to clear *all* calibration data. The **Cc** (Clear Calibration) code will display and the control will exit **Cc** mode automatically.

### Adjust LED Brightness Level (LS and SL Codes)

The brightness setting of the cab control lights can be adjusted from 1 to 16. The factory default setting is 8.

1. Turn the vehicle ignition to ACC or ON. If necessary, press the cab control ON/OFF button to turn the control OFF.
2. Press and hold the Material Width (left) knob for approximately 3 seconds until the **LS** code is displayed.
3. Release the knob and turn it clockwise or counterclockwise to increase/decrease the brightness level. The light level number will show in the status display.
4. After selecting the desired brightness level, wait a few seconds for the **SL** confirmation code to display.

---

**NOTE: A brightness level setting of 12 or higher is recommended for daylight conditions.**

---

---

# POLY CASTER™

## POLY HOPPER SPREADERS

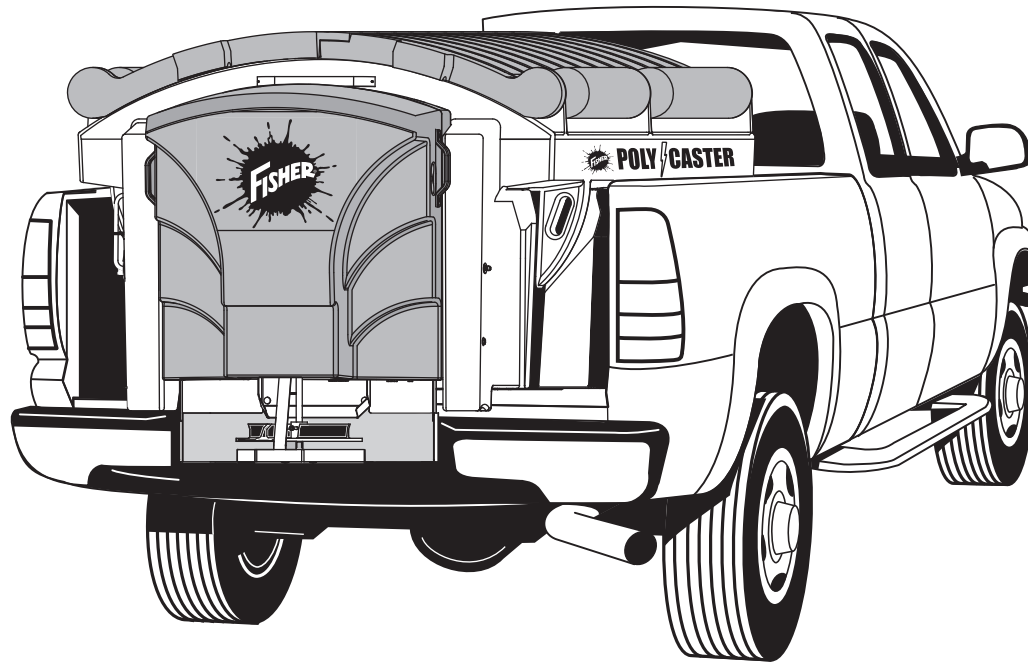

## POLY HOPPER SPREADERS – REMOVING THE SPREADER

### ⚠ CAUTION

Before lifting, verify that hopper is empty of material. The lifting device must be able to support the spreader's weight as shown in the spreader specifications table of the spreader Owner's Manual.

1. The spreader can be removed from the truck bed either by lifting the spreader by the four molded-in handles located on the corner legs or by sliding the spreader out of the truck bed onto the ground.
2. First make sure all material has been removed from the spreader and the chute is detached. To empty the spreader and remove the chute:
  - a. Remove the two pins that hold the chute to the hopper body.
3. Disconnect the electrical connections at the spreader.
4. Remove any means used to attach the spreader to the truck bed and ensure that the lids are closed securely.
5. To remove the spreader without a lifting device, two or more people are recommended. Move spreader rearward until it balances at the rear of the bed. Carefully lower the back of the spreader to the ground so that it is resting on its feet.
6. Tip the spreader up onto spacers at least 2" tall, so that it is fully supported by the feet.

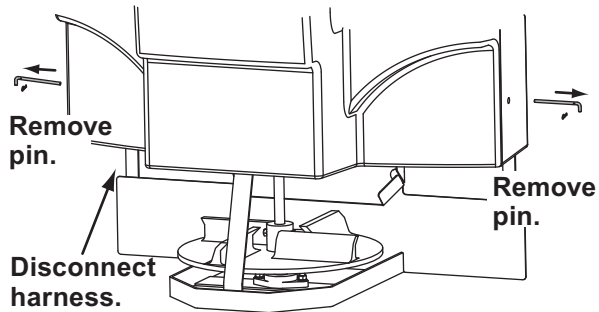

- b. Disconnect the spinner motor connector.
- c. Grasp the chute, raise it, and remove it from the hopper body.
- d. Operate the hopper to convey all material from the spreader.
- e. Remove the sill deflectors by loosening the bolts for the bearing and gear box. Slide out the deflectors and tighten the bolts.

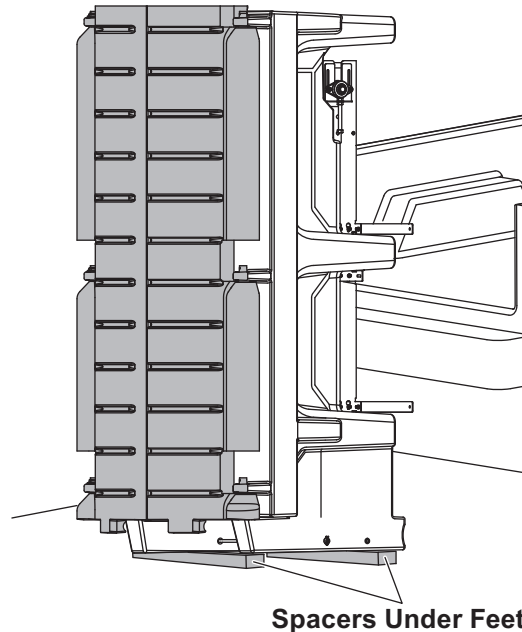

7. **Do not leave an unsecured spreader standing on its feet.** After pulling the truck away, either lower the spreader so that it is resting on its six legs or properly support it with blocks and secure it as directed in the Storage section of this manual. If lowering the spreader onto its six legs, place spacers under the legs so that the feet at the rear of the spreader are off the ground.

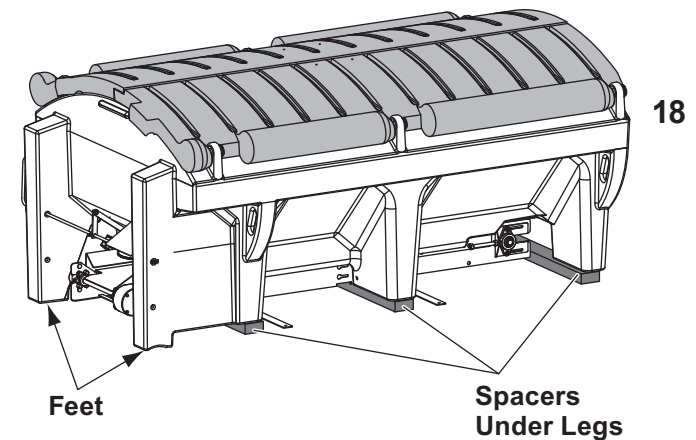



## POLY HOPPER SPREADERS – STORAGE

The spreader can be stored on end (on its feet) for storage; however, steps must be taken to properly support it with blocks and secure it.

### **⚠ CAUTION**

**Before lifting, verify that the hopper is empty of material. The lifting device must be able to support the spreader's weight as shown in the spreader specifications table of the spreader Owner's Manual.**

1. Back the truck near a wall, fence, or other permanent structure so that there is enough room to remove the spreader but the spreader will be against the structure when it is taken out of the truck.

2. Remove the spreader from the truck following the instructions in the Removing the Spreader section of this manual.
3. Add blocks supporting the sides of the hopper body and conveyor, as shown.

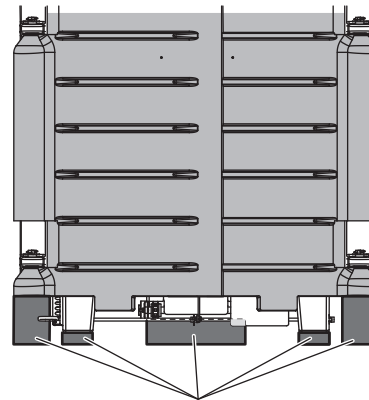

**Support sides and conveyor with blocks.**

4. Secure the spreader to the structure using chains or straps to ensure that it cannot tip or fall.

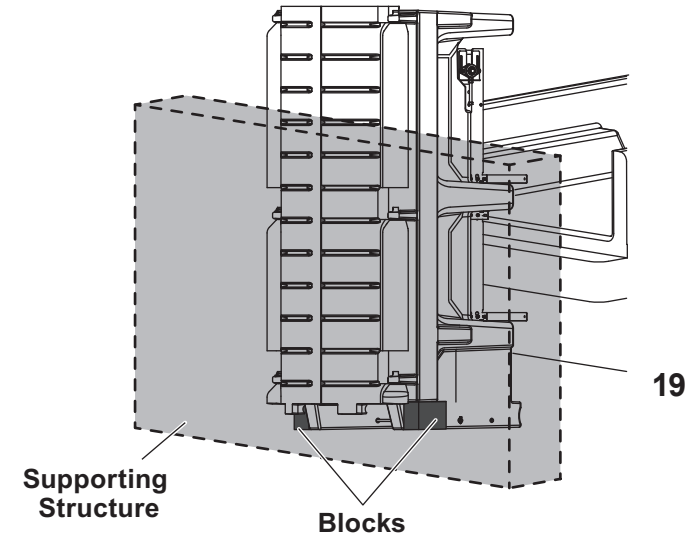

## POLY HOPPER SPREADERS – MAINTENANCE

### ⚠ CAUTION

Disconnect electric power at spreader electrical wiring harness connection and tag out if required before servicing or performing maintenance.

### GREASE FITTINGS

To keep your spreader running smoothly, lubricate grease fittings after each use and at the end of each season.

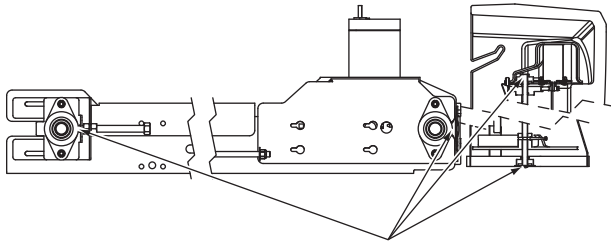

Grease after each use with a good quality multipurpose grease.

### CONVEYOR PINTLE CHAIN TENSION

1. Periodically check the conveyor chain tension. The spreader should be out of the vehicle. To check the tension, measure in 20"–24" from the rear edge of the sills. Push up on the chain with your hand. The conveyor chain should lift up 1"–3" off the conveyor chain guide.
2. If the slack is greater than 3", loosen the two bearing mounting bolts on each side of the conveyor idle roller on cab end of hopper.
3. Loosen the jam nut on one of the take-up bolts, then tighten (clockwise) the take-up bolt one full revolution. Retighten jam nut. Repeat evenly on the other side.

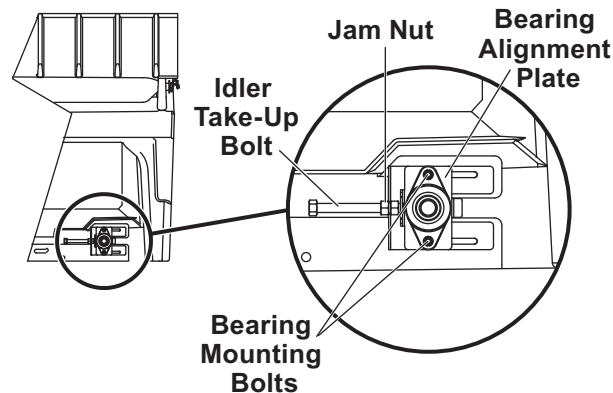

### AFTER EACH USE

### ⚠ CAUTION

**DO NOT** leave unused material in hopper. Material can freeze or solidify, causing unit to not work properly. Empty and clean after each use.

- Wash out the hopper and rinse off all external surfaces.
- Clean out any trapped/frozen material from between the pintle chain and the vehicle bed surface.
- After each use, and at the beginning and end of the season, apply dielectric grease on all electrical connections to prevent corrosion.
- Lubricate all grease fittings with good quality multipurpose grease.

# POLY HOPPER SPREADERS – CONTROLLING MATERIAL APPLICATION

---

The material application settings can be adjusted while spreader is ON or OFF. Settings are shown by the indicator lights around the control knobs. When the spreader is OFF, a single LED will light to show the current setting. When the spreader is ON, the number of blue LEDs illuminated will increase/decrease as the knobs are turned clockwise/counterclockwise.

The hopper drive will not deliver material until the ON button is pressed.

The Material Width (left) knob controls spinner speed. Turning the knob clockwise will increase the width of the application area.

The Material Flow (right) knob controls the hopper drive. Turning the knob clockwise will increase the feed rate of material to the spinner.

Turning the control knobs counterclockwise will decrease the width of the application area and the feed rate of material.

## BLAST/Maximum Application

1. Press and hold the BLAST button when maximum flow rate and application area are needed temporarily. The BLAST button will illuminate while depressed.
2. Release the button when maximum application settings are no longer needed.

---

**NOTE: Spinner speed and material feed rate revert to the previous settings once the BLAST button is released.**

---

## CAB CONTROL MODES

### Standby Mode

Vehicle ignition is set to ACC or ON; cab control is OFF. Control has power. No spreader was detected. No lights are illuminated on the control. Press any button to wake.

### Ready Mode

Vehicle ignition is set to ACC or ON; cab control is OFF. Control has power. Spreader is detected.

The Material Width and Material Flow control knobs can be set to start-up conditions, but the spinner and drives will not operate until the cab control is turned ON.

Accessory lights and vibrator (if installed) are operational. The BLAST function is not operational.

### ON Mode

Vehicle ignition is set to ACC or ON; cab control is ON.

Spinner and hopper motors will start. All cab control functions are operational. Accessory lights and vibrator (if installed) are operational.

During normal spreader operation, **no control codes are displayed**. Information or setup codes will appear when relevant. These codes will not stop spreader operation.

### Error Mode

When an error condition occurs, spreader operation will shut down. A two-digit error code will flash on the display and a beep will sound. If there are multiple error codes, the codes will flash in a repeating sequence.

Refer to the Error Codes beginning on page 14 of the Cab Control Codes table. Also see the Troubleshooting Guide section of this manual.

Once the error condition has been resolved, press the ON/OFF button to clear the error code(s). Press the ON/OFF button again to resume spreader operation.

The error code will reappear if the error condition has not been rectified. If the error condition persists, contact your authorized dealer.

Multiple resets within a short time frame will cause the hopper module to time out if components are overheating. The control will display an **EF** error code.

Accessory work lights and strobe lights can be used when an error code is in effect and will remain in their current state. The vibrator and pre-wet will not function.

# POLY HOPPER SPREADERS – TESTING

---

## MODULE TEST:

Check for input of power and ground (minimum 12V) to module. Turn control knobs to full and check for output to conveyor and spinner motor.

## CONTROL TEST:

Verify control is receiving power and ground (minimum 12V).

## HOPPER MOTOR TESTING (FLEET FLEX ELECTRICAL SYSTEM)

### Tools Needed:

- Multimeter with an ampere clamp rated at no less than 400A

Before starting any testing, verify that the battery and charging system of the vehicle are functioning correctly. This includes checking that all electrical connections are clean and tight. If not, correct the issue before testing.

Verify that there are no mechanical issues with the spreader.

Examples: bearings, stiff or damaged conveyor chain, dry gear box, or conveyor chain that is too tight.

All of these will cause increased amperage draw.

**Testing motor amperage draw:** Connect the ampere clamp of the meter to either wire motor lead, POSITIVE (+) or NEGATIVE (-). Operate the spreader at the highest setting on the control.

### Conveyor Motor

10–18A empty

30–45A loaded

### Spinner Motor

5–10A empty

10–15A loaded

---

**NOTE: Loaded spinner amperage may not run steady due to the way some materials will drop on the spinner (meaning clumps of material vs. free-flowing material).**

---

# POLY HOPPER SPREADERS – TESTING

## POLY HOPPER SPREADER HARNESS TESTING PROCEDURE (FLEET FLEX SYSTEM)

### Tools Needed:

- Multimeter
- Jumper wire

Before running any electrical tests on the spreader, verify that the vehicle battery and charging system are working correctly, that there are no broken, chafed, or corroded wires, and that the spreader has no mechanical issues.

Check the routing of all spreader-related vehicle harnesses, making sure they are not routed next to any vehicle body control modules or any other high frequency systems, two-way radio power leads, or antenna wires.

When testing harnesses, take care not to cause any damage to the wires, pins, or connectors.

### Checking Vehicle Control Harness

1. Disconnect the vehicle control harness from the control and the vehicle spreader harness/battery cable.
2. At the black 6-pin connector, check for continuity between all pins 1–5. **There should NOT be any trace of continuity between any combinations of these wires.**
3. Take the jumper wire and connect it between pins 2 and 3 of the white 4-pin connector in the cab. Connect the meter between pins 2 and 3 of the black 6-pin connector. The meter should read continuity.

**NOTE: If the harness fails any of the above tests, replace the harness.**

4. With the meter ground lead connected to a vehicle ground, turn the key ON and check for 12V on pin 5 at the black 6-pin connector. Then check for battery voltage on pin 1 of the white 4-pin connector in the cab.

**NOTE: If battery voltage is missing, repair or replace as needed.**

5. Check for continuity between pin 1 at the black 6-pin connector and pin 4 of the white 4-pin connector in the cab.
6. If the orange CHMSL wire is connected to the brake lighting circuit in the cab of the vehicle, depress the brake pedal and check for 12V on the black 6-pin connector at pin 4.

**NOTE: Not all vehicles will connect in the cab. Some may need to be connected at the rear of the vehicle. Check the body builder's guide pertaining to the make of the vehicle.**

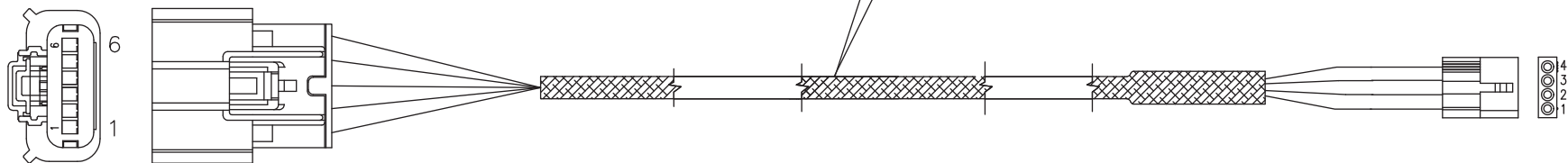

## POLY HOPPER SPREADERS – TESTING

### Checking Vehicle Spreader Harness

1. Disconnect the vehicle spreader harness from the vehicle control harness at the black 6-pin connector. Disconnect the vehicle spreader harness from the 8-pin spreader harness at the rear of the vehicle. Leave the POSITIVE (+) and NEGATIVE (-) battery leads connected to the battery.
2. At the 8-pin connector, check for continuity between all pins 3–8. **There should NOT be continuity between any combinations of these wires.**
3. Take the jumper wire and connect it between pins 2 and 3 of the black 6-pin connector. Now connect the meter between pins 6 and 7 of the black 8-pin plug. The meter should read continuity.
4. With a multimeter, check for battery voltage at pins 1 and 2 of the 8-pin plug. If the voltage is low, or if no power exists, check for loose or corroded connections at the vehicle battery and at the 100A mega fuse.
5. With the positive lead of the meter connected to pin 1 of the black 8-pin plug, take the black lead and check pin 8 of this plug for battery voltage. Also check pin 1 of the black 6-pin connector for battery voltage.
6. Take the jumper wire and connect it between pins 1 and 3 of the 8-pin plug. Now at the black 6-pin connector, check for battery voltage. Use the tester on pin 5 and pin 1.

7. To check the license plate light, turn on the parking lights, and check for battery voltage at pin 4.
8. If the orange CHMSL wire is connected to the brake lighting circuit at the rear of the vehicle, depress the brake pedal and check for battery voltage at pin 5 of the black 8-pin plug.

**NOTE: Not all vehicles will connect at the rear of the vehicle. Some may need to be connected in the cab. Check the body builder's guide pertaining to the make of the vehicle.**

**NOTE: If the harness fails any of the above tests, replace the harness.**

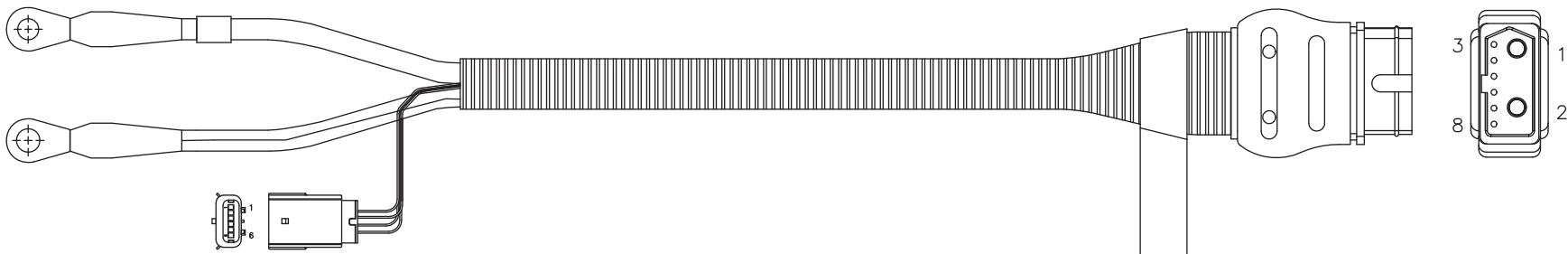

# POLY HOPPER SPREADERS – TESTING

## Checking Spreader Harness Assembly

1. Disconnect the spreader harness from the vehicle spreader harness and from ports A and B of the spreader module.
2. Visually inspect the wiring harness for damage.
3. At the 8-pin connector, check for continuity between all pins 3–8. **There should NOT be any trace of continuity between any combinations of these wires.**
4. Check the switched accessory wire for continuity from pin 3 at the 8-pin plug to pin F at the 10-pin connector.
5. Check the battery ground wire for continuity from pin 8 at the 8-pin plug to pin K at the 10-pin connector.
6. Check the orange CHMSL wire for continuity from pin 5 at the 8-pin plug to the orange wire at the CHMSL light.

7. Check the plate light wire for continuity from pin 4 at the 8-pin plug to the brown wire at the plate light.
8. Take the jumper wire and connect it between pins B and C of the black 10-pin connector. Connect the meter between pins 6 and 7 of the black 8-pin plug. The meter should read no continuity.

**NOTE: If the harness fails any of the above tests, replace the harness.**

9. To check the chute present connection, verify that the gray 4-pin connector leading from the module is connected to the gray 4-pin connector leading to the chute. Connect the black lead of the meter to the black wires on the GND post of the spreader module. Connect

the red lead to pin 8 of the 10-pin connector. There should be continuity. If no continuity is seen, disconnect the gray connectors. Take the connector leading from the spreader and using the jumper wire, connect between pins B and C. Then recheck for continuity. There should be continuity. If no continuity is found, replace the chute harness.

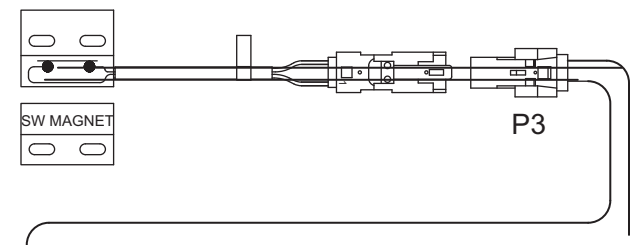

10. To check the dump switches, connect the black lead of the meter to the black wires on the GND post of the spreader module. Connect the red lead to pin E of the 10-pin connector. Push both dump switches at the same time. There will be continuity. If there is not continuity, disconnect the harness from each of the dump switches. Check each switch for continuity by connecting the meter to each terminal, then pushing the button. If no continuity is found, replace the switch.

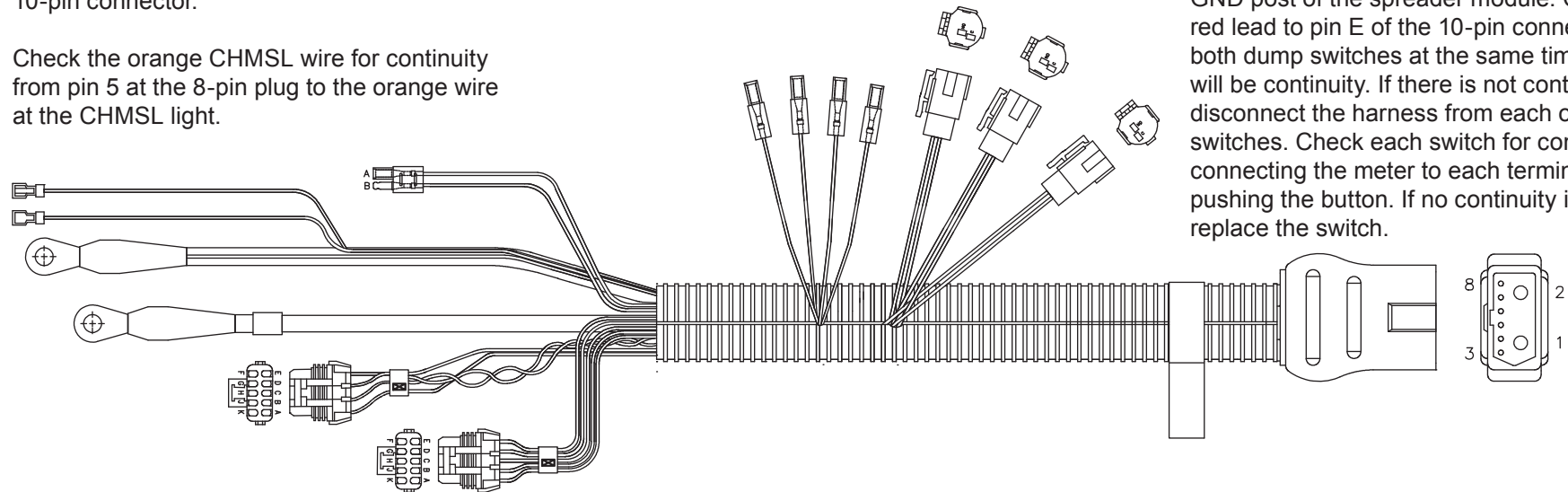

## POLY HOPPER SPREADERS – TROUBLESHOOTING GUIDE

Please see your distributor for service. The troubleshooting reference table below may guide you in diagnosing the issue.

For a reference table of the cab control error codes, see the Operating the Hopper Spreader – Cab Controls section of this manual.

Before servicing the spreader:

- Review all safety information.
- Confirm that all electrical connections are tight and clean.
- Confirm that nothing is jammed in the hopper.

Problem	Possible Cause	Suggested Solution
<b>No power to cab control.</b> Ignition and control switches ON; control knob indicator lights not illuminated.	1. Control connector plug is loose.	1. Check plug connection at cab control.
	2. Switched accessory connection is poor or faulty.	2a. Check for low battery voltage. 2b. Check switched accessory connection.
	3. Vehicle control harness is damaged.	3. Repair or replace damaged wires or harness as required.
<b>Turning control knobs does not change motor speed.</b>	1. Malfunctioning cab control.	1. Replace cab control.
	2. Malfunctioning spreader module.	2. Replace spreader module.
	3. Check for damaged harnesses.	3. Replace harnesses.
<b>Spreader does not operate.</b>	1. Check error codes.	1. Refer to error codes troubleshooting table.
	2. Wire harness is damaged or has an open circuit between cab control and spreader.	2a. Check plug connections at cab control and spreader. 2b. Check wire connections at spreader motor and at vehicle battery: disconnect motor leads, turn Material Width and Material Flow knobs to maximum, and check for voltage at motor leads. 2c. Repair or replace damaged wires and connectors. 2d. Check the 100A in-line fuse on the 22" red cable. Replace if necessary.
<b>Spinner does not turn.</b>	<b>Unplug the spreader harness and tag out, if required, before performing any of the following repairs.</b>	
	1. Obstruction is preventing rotation.	1. Clear obstruction.
	2. Drive belt is loose or damaged.	2. Adjust the tension or replace the belt if worn or damaged.
	3. Motor pulley is not secured to motor shaft.	3. Tighten the pulley set screw or replace the pulley if damaged.
	4. Spinner pulley is not secured to spinner shaft.	4. Tighten the pulley set screw or replace the pulley if damaged.
	5. Spinner shaft bearings are dry or seized.	5. Grease or replace bearings.

Table continues on next page.



# POLY HOPPER SPREADERS – TROUBLESHOOTING GUIDE

*Poly Hopper Spreaders Troubleshooting (continued)*

Problem	Possible Cause		Suggested Solution
<b>Conveyor chain not moving.</b>	<b>Unplug the spreader harness and tag out, if required, before performing any of the following repairs.</b>		
	1. Obstruction is preventing rotation.	1. Clear obstruction.	
	2. Gear box is damaged.	2. Replace gear box if output shaft does not turn when motor shaft turns.	
	3. Conveyor sprockets are not secured to shafts.	3. Replace or tighten set screws. Replace shafts or sprockets if damaged.	
	4. Conveyor pintle chain is loose or damaged.	4. Adjust pintle chain tension. Replace pintle chain if damaged.	
	5. Conveyor pintle chain is not aligned.	5. Align pintle chain to ride centered on rollers.	
<b>Material in hopper does not flow.</b> Conveyor pintle chain and spinner are moving.	<b>Unplug the spreader harness and tag out, if required, before performing any of the following repairs.</b>		
	1. Feed gate is closed.	1. Open feed gate fully, then adjust to desired opening size.	
	2. Obstruction in hopper.	2. Clear obstruction.	
	3. Material frozen or bridged.	3. Clear the frozen or bridged material.	

# POLY HOPPER SPREADERS – ELECTRICAL SYSTEM

## POLY HOPPER HARNESS / CABLE ASSEMBLIES

LOCATION: NEAR VEHICLE  
BATTERY CONNECTIONS

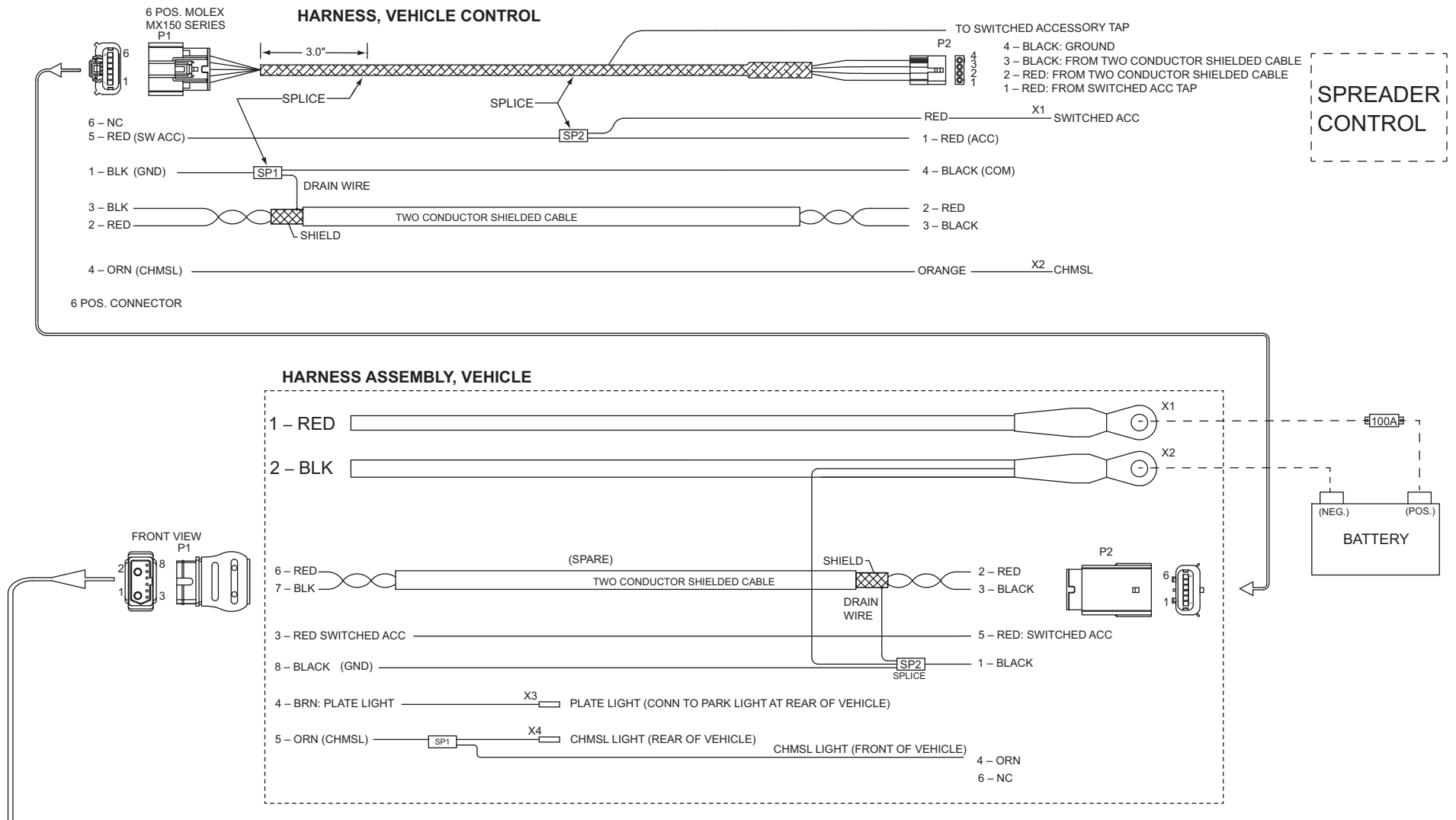

# POLY HOPPER SPREADERS – ELECTRICAL SYSTEM

## POLY HOPPER HARNESS / CABLE ASSEMBLIES

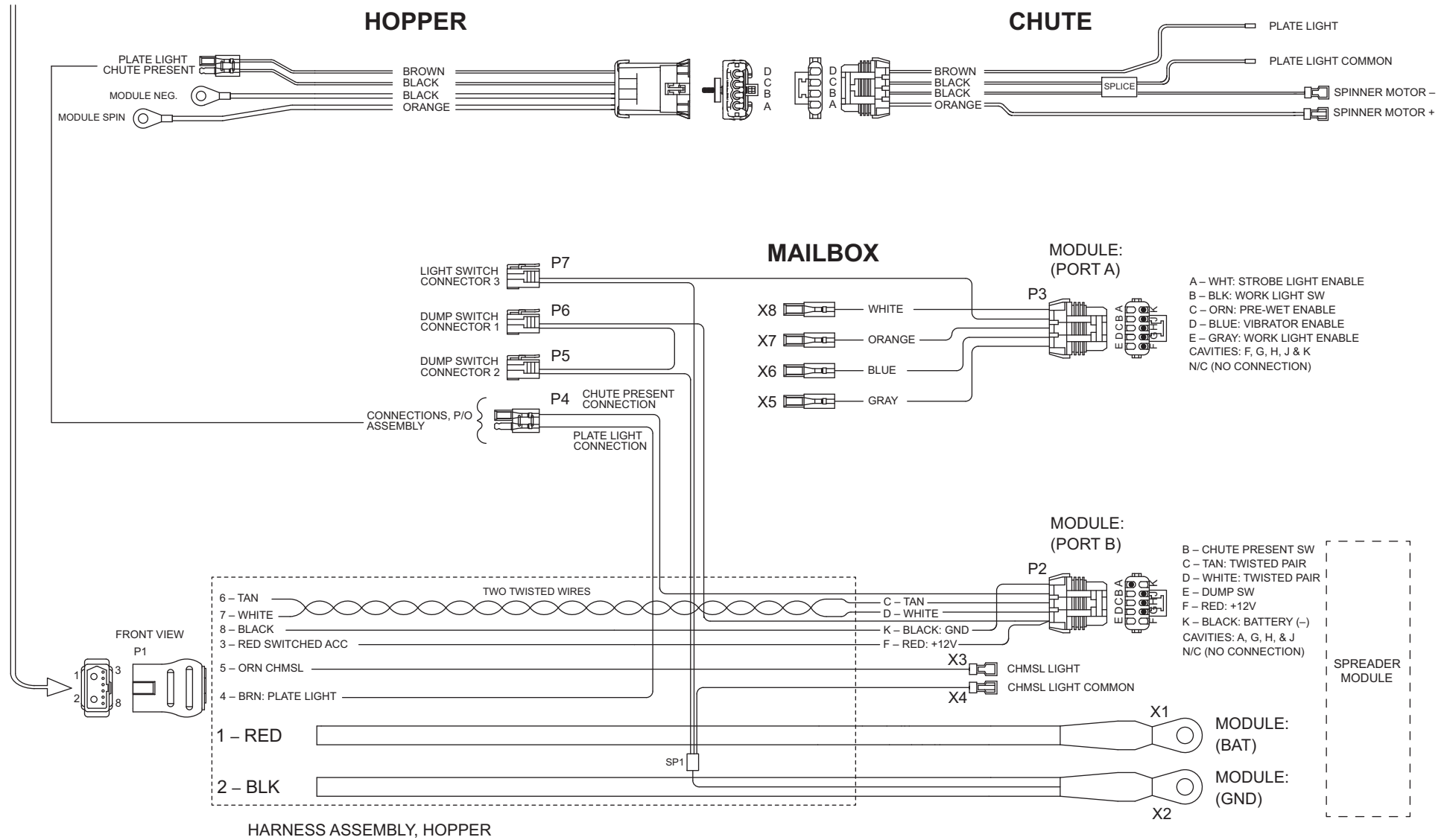

# POLY HOPPER SPREADERS – ELECTRICAL SYSTEM

## WIRING – VEHICLE HARNESS DIAGRAM

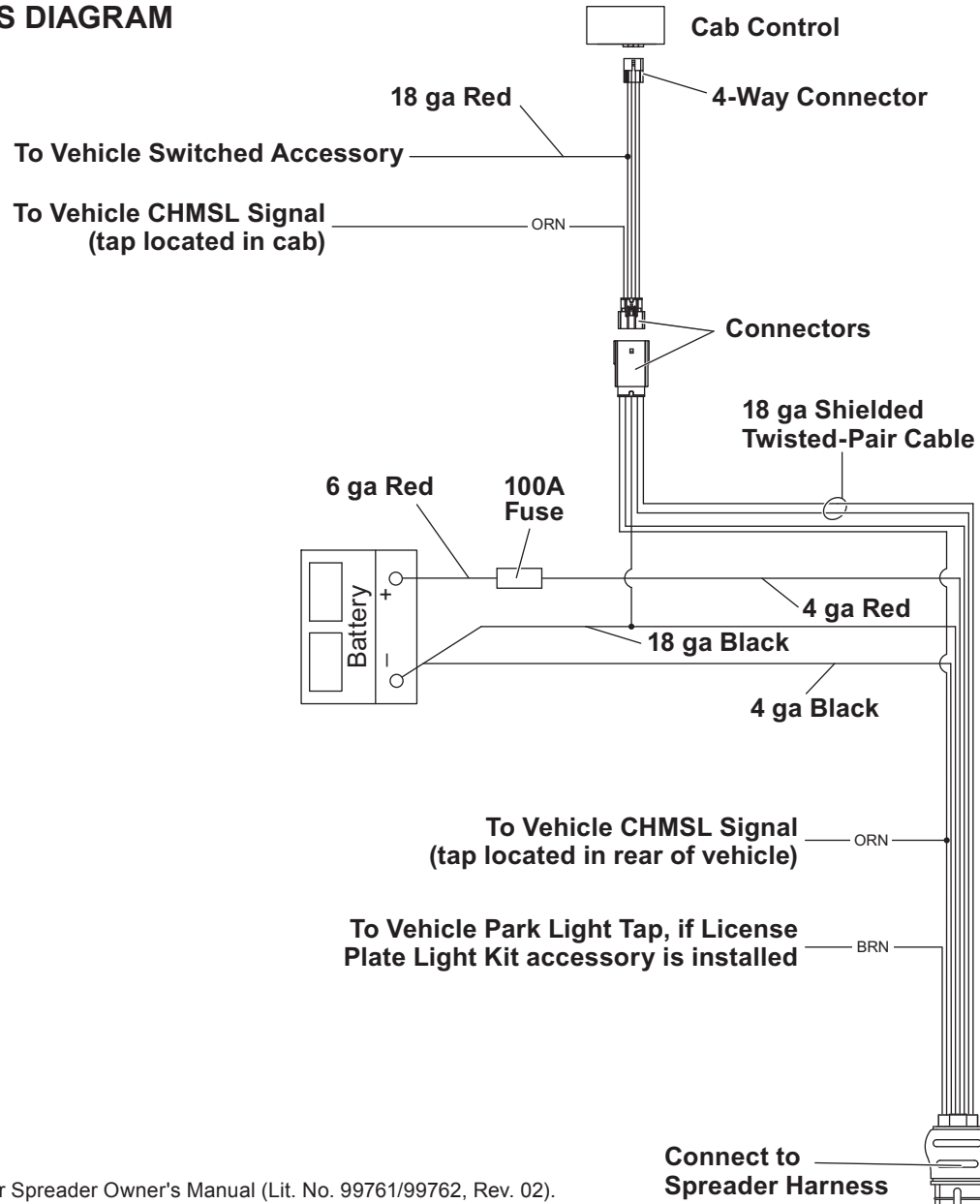

# POLY HOPPER SPREADERS – ELECTRICAL SYSTEM

## HARNESSING COMPONENTS

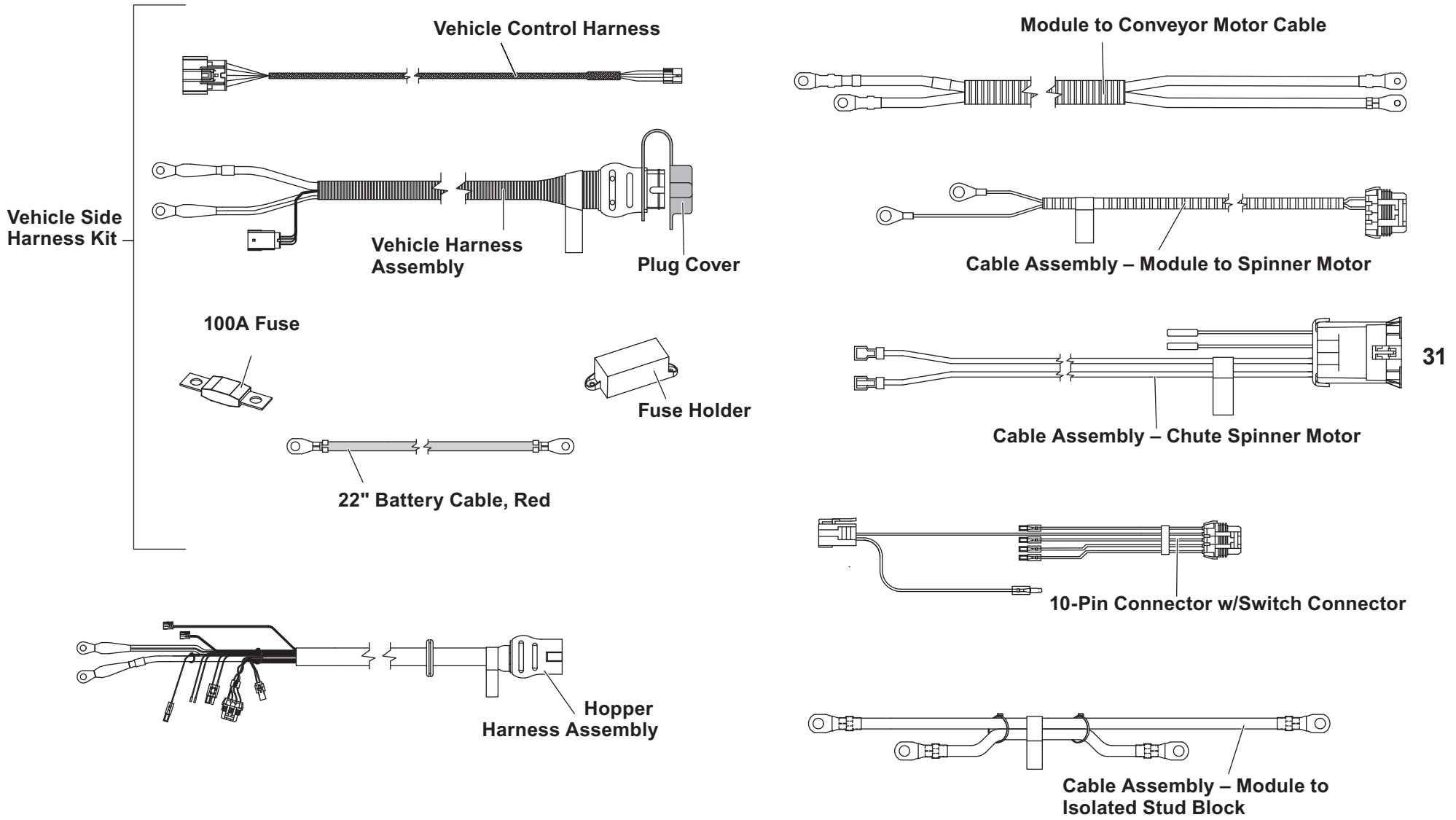

Excerpts taken from POLY-CASTER™ Hopper Spreader Parts List (Lit. No. 99754, Rev. 04).

# POLY HOPPER SPREADERS – ELECTRICAL SYSTEM

## MODULE BOX HARNESS ROUTING DIAGRAM

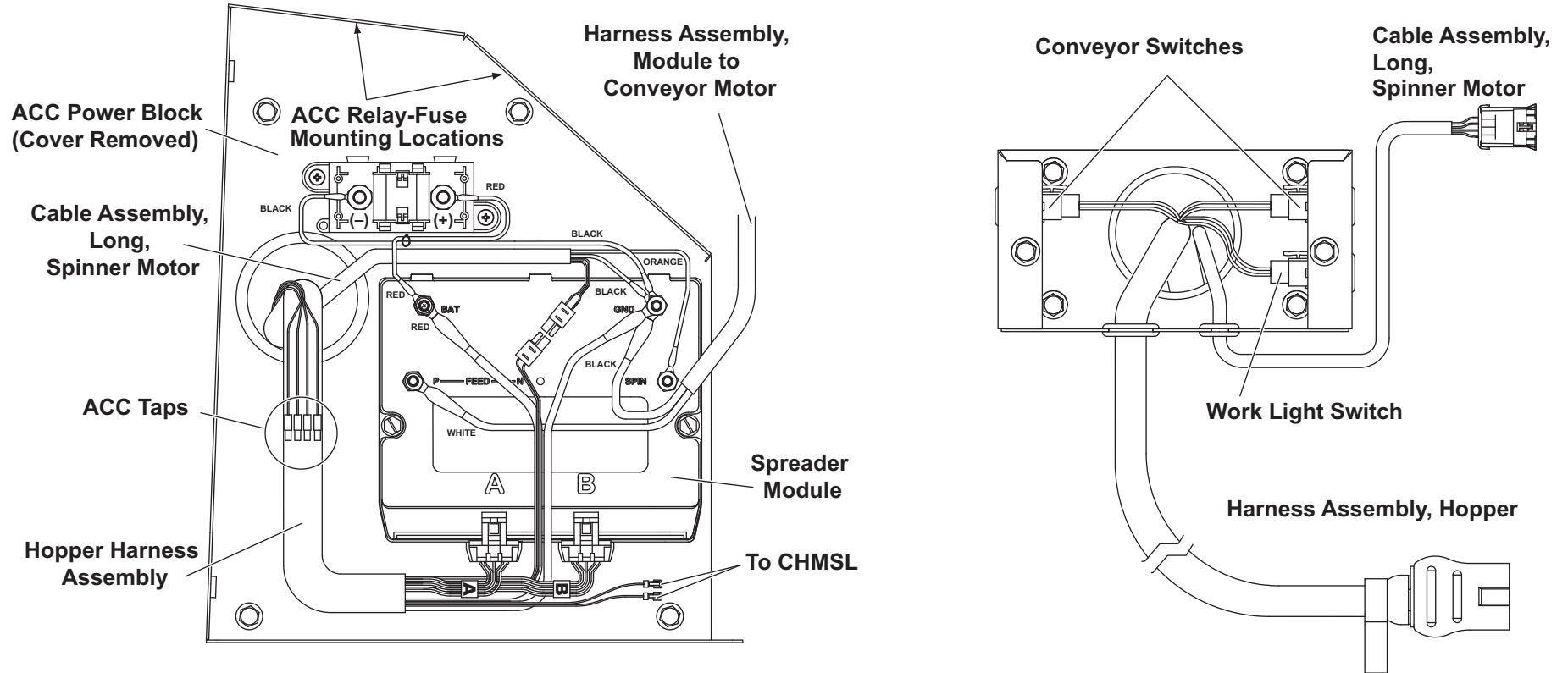

# POLY HOPPER SPREADERS – SPINNER MOTOR REPLACEMENT

---

## REPLACING THE SPINNER MOTOR

1. Disconnect the chute electrical harness and remove the chute from the spreader.
2. Remove the chute motor cover to expose the spinner motor, pulleys, and belt.
3. Remove the spinner belt from the spinner and motor pulleys by swinging the motor towards the spinner pulley.
4. **If the motor is in need of replacement:** Disconnect the wire harness at the spade connectors. Remove the two #10-32 locknuts and washers that attach the motor to the base plate.
5. Pull the motor with the pulley attached out of the motor base plate.
6. Reinstall the new motor with the pulley attached using two #10-32 locknuts and washers. Reconnect the harness to the motor.
7. Turn the spinner shaft by hand, ensuring that it moves freely. Check for looseness in the shaft bearings. Repair as needed. Grease both upper and lower shaft bearings.
8. Reinstall the spinner belt over both the motor and shaft pulleys. Confirm that the pulleys are aligned with each other and that the belt is running true. If adjustment is needed, loosen the set screw on the motor pulley and adjust the pulley up or down as required. Retighten the set screw.
9. Reinstall the chute motor cover.
10. Reinstall the chute on the spreader.
11. **Run the spreader to verify correct operation. Pay attention to the spinner. It should turn in a counterclockwise rotation. If not, swap the spade connections at the motor.**

---

**NOTE: The spinner motor tensioner is spring loaded.**

---

# POLY HOPPER SPREADERS – GEAR BOX

## SERVICING THE GEAR BOX

### ⚠ CAUTION

Disconnect electric power at spreader electrical wiring harness connection and tag out if required before servicing or performing maintenance.

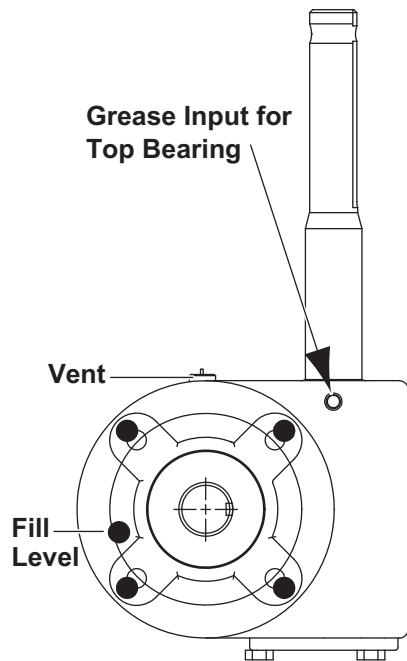

## LUBRICATION

### ⚠ CAUTION

Over-greasing may cause seal damage. The gear case must be filled to the oil-level plug with Mobil SHC 632, Exxon SHP 320, or equivalent synthetic gear-type lubricant. Keep the breather plug clean.

- After every 10 hours of operation, grease the idler bearings on the idler shaft, the flanged bearings on the drive shaft, and the spinner shaft bearings.
- After every 50 hours of operation, grease the input shaft bearing on the gear case and verify that the oil level of the gear case is level with the fill hole.
- Change the chain drive gear case oil once a year. Drain the oil by removing the drain plug and oil level plug. Refill from the bottom drain hole with Mobil SHC 632, Exxon SHP 320, or equivalent synthetic gear oil until fluid comes out of the oil level hole. Reinstall plugs.

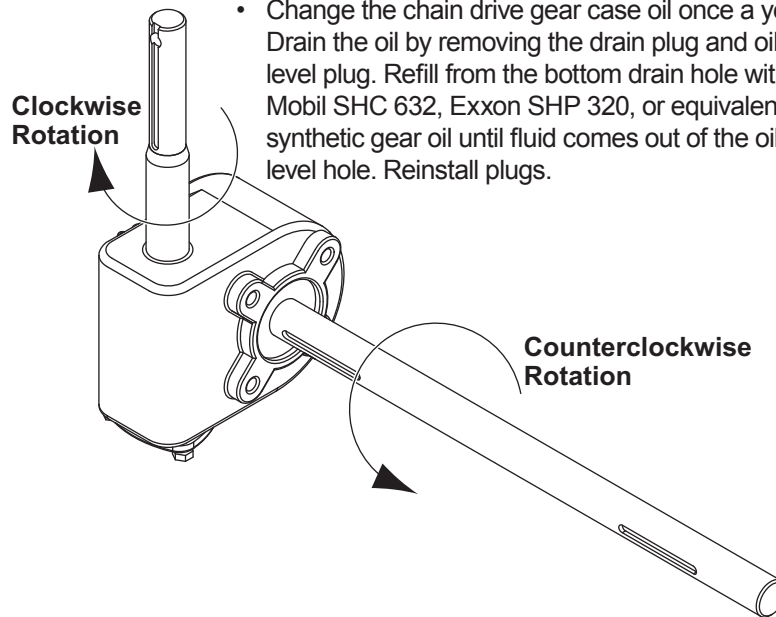

## GEAR OIL SPECIFICATION

Use Mobil SHC 632 or Exxon SHP 320 or equivalent.

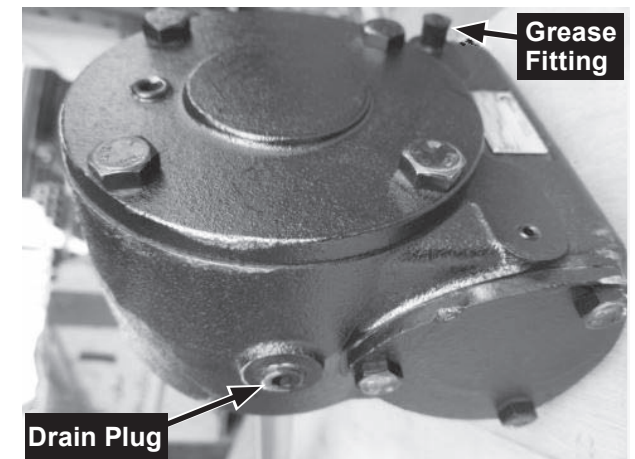
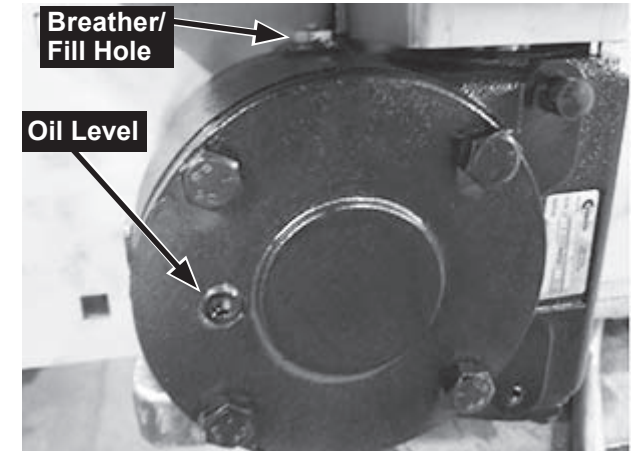



# POLY HOPPER SPREADERS – GEAR BOX ASSEMBLY: FLEET FLEX SYSTEM

## REPLACING THE GEAR BOX

**NOTE: Disconnect the spreader electrical harness from the vehicle harness before making any repairs to the unit.**

**NOTE: Spreader gear box is sealed and not serviceable.**

### Removing the Gear Box Assembly

1. Disconnect the power and ground wires from the conveyor motor. Remove the motor from the primary gear box.
2. Loosen the fasteners on each of the idler shaft bearings located at the front of the spreader on both sides of the sill.
3. Loosen the jam nuts on the take-up bolts. Back off the bolts enough to allow the idler shaft to slide back evenly. This will allow the conveyor chain to slacken.
4. At the secondary gear box (lower) remove the black plastic cover exposing the end of the drive shaft. Remove the 1" retaining ring (e-clip) from the end of the drive shaft.
5. Remove the four fasteners that mount the gear box mounting plate to the sill.
6. Pull the gear box assembly out. The drive shaft will remain in place. You may need to lightly tap on the end of the shaft to get it started. Be careful not to damage the end of the shaft.

7. Remove the four bolts that mount the gear box assembly to the mounting plate.

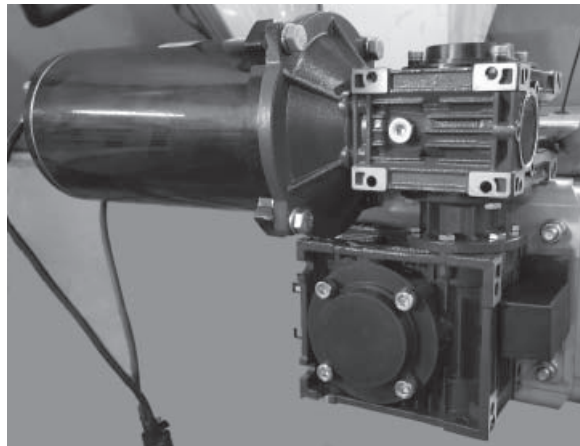

### Installing Gear Box

1. Mount the gear box assembly to the gear box mounting plate using four M8-1.25 x 16 mm cap screws with lock washers.
2. Coat the drive shaft with an anti-seize material. Line up the keyways and slide the gear box assembly onto the drive shaft. To aid in aligning the keyways, turn the input shaft of the primary gear box.
3. Using four 5/16"-18 x 3/4" carriage bolts with nuts and lock washers, attach the gear box mounting plate to the sill.
4. Install the 1" retaining ring (e-clip) on end of drive shaft and reinstall the cover.

5. Install the motor to the gear box assembly using four 3/8"-16 x 3/4" cap screws with lock washers.
6. Connect the power and ground wires to the motor.
7. Tighten the take-up bolts evenly from side to side until the conveyor chain is visible through the chain tension port. You should be able to lift up the chain 1"-3" at approximately 20"-24" from the rear of the spreader.

**NOTE: Adjusting the conveyor chain too tight will increase amperage draw.**

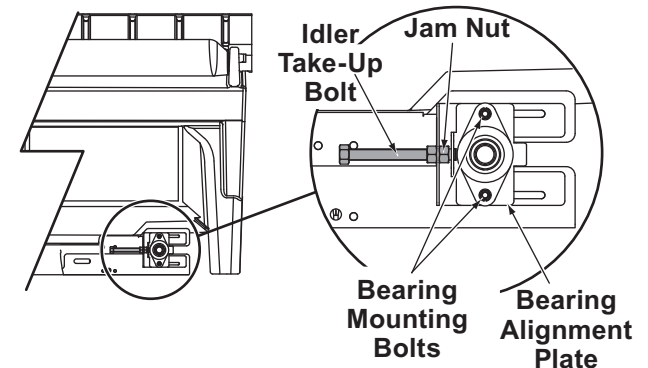

8. Once the correct chain tension has been achieved, tighten the four bearing mounting bolts.
9. Run the spreader to verify the conveyor chain tension and alignment, paying close attention to the conveyor chain direction. If the conveyor is turning in the wrong direction, swap the power and ground wires to change the direction.

# POLY HOPPER SPREADERS – CONVEYOR CHAIN: FLEET FLEX SYSTEM

## REPLACING THE CONVEYOR CHAIN

**NOTE: For Gas Models: Remove the spark plug wire and isolate. For Electric Models: Disconnect electrical connections. For Hydraulic Models: Disconnect hydraulic hoses.**

### Removing the Conveyor Chain

1. Locate the master link in the conveyor chain. Rotate the chain until the master link is at the drive sprockets.
2. Loosen the fasteners on each of the idler shaft bearings located at the front of the spreader on both sides of the sill.
3. Loosen the take-up bolts enough to allow the idler shaft to slide back evenly. This will allow the conveyor chain to slacken.
4. Remove the cotter pins from the master link on each side. Pull each link pin out. There may still be some tension on the pin due to the weight of the chain.
5. Tie a rope to the bottom end of the existing conveyor chain. Holding the top end of the chain, pull the chain out. It may take two people to remove the chain. The rope will feed up through, which will make it much easier for installing the replacement chain.

### Installing the Conveyor Chain

1. Inspect all bearings, idler shaft, etc., before installing the conveyor chain.
2. Starting with the closed link on the end of the chain, tie the end of the rope on the top side of the sill to the chain, making sure that the offset in the crossbar is facing down.
3. Pull on the other end of the rope while guiding the chain up over the drive sprockets. It may take two people to install the chain. Make sure the chain is positioned correctly into the idler sprockets at the front of the spreader.
4. Once you have pulled the chain into position, install the link pins with cotter pins, separating and bending both legs of the cotter pin.
5. Tighten the take-up bolts evenly from side to side until the conveyor chain is visible through the chain tension port. You should be able to lift up the chain 1"–3" at approximately 20"–24" from the rear of the spreader.
6. Once the correct chain tension has been achieved, tighten the four bearing mounting bolts.

7. Run the spreader to verify that the chain tension is correct and running true. Make adjustments as needed.

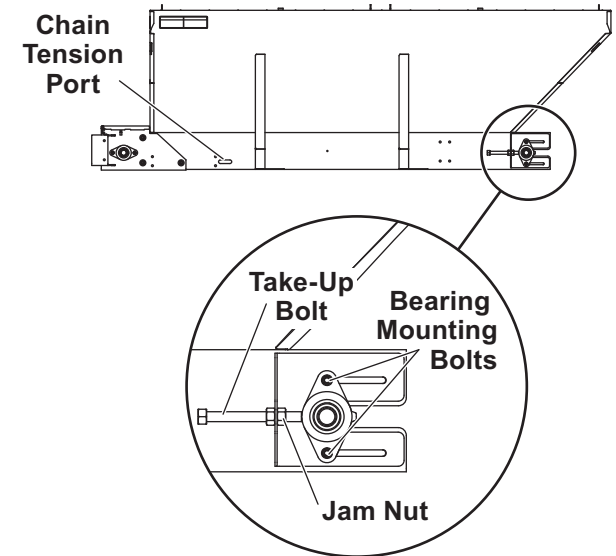

**NOTE: Having the conveyor chain too tight will put additional load on the entire drive system and will increase the amperage draw on electric units.**

**NOTE: On electric units, make sure to calibrate the empty hopper function of the control.**



# STAINLESS STEEL HOPPER SPREADERS

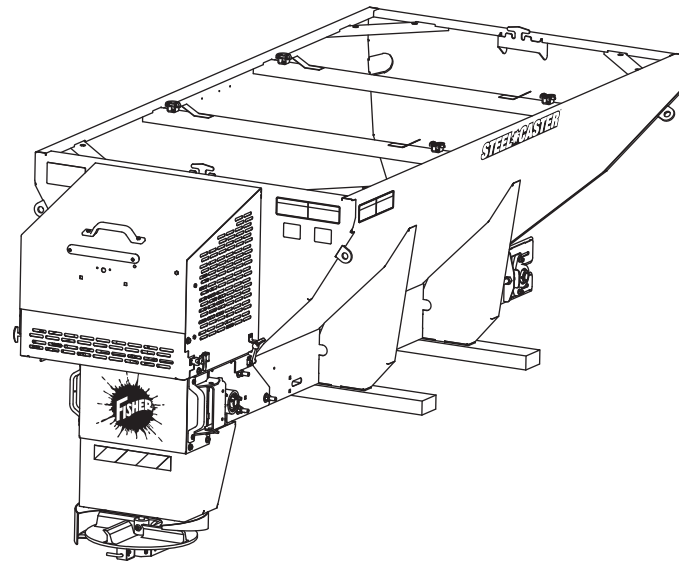
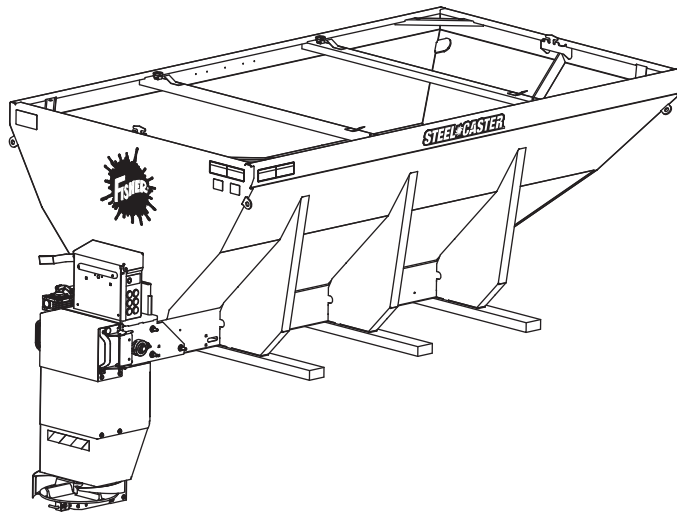

# STEEL HOPPER SPREADERS – TESTING

## STEEL HOPPER SPREADER HARNESS TESTING PROCEDURE (FLEET FLEX SYSTEM)

### Tools Needed:

- Multimeter
- Jumper wire w/2 small alligator clips

Before running any electrical tests on the spreader, verify that the vehicle battery and charging system are working correctly, and that there are no broken, chafed, or corroded wires. Also verify that the spreader has no mechanical issues.

Check the routing of all spreader-related vehicle harnesses, being sure they are not routed next to any vehicle body control modules, communication lines, or two-way radio power, antenna wires, or any other high frequency systems.

When testing harnesses, take care not to cause any damage to the wires, pins, or connectors.

### Checking Vehicle Control Harness

1. Disconnect the vehicle control harness from the control and the vehicle spreader harness/battery cable.
2. Visually inspect the wiring harness for damage.
3. At the black 6-pin connector, check for continuity between all pins 1–5. **There should NOT be any trace of continuity between any combinations of these wires.**
4. Take the jumper wire and connect it between pins 2 and 3 of the white 4-pin connector in the cab. Now connect the meter between pins 2 and 3 of the black 6-pin connector. The meter should read continuity.

**NOTE: If the harness fails any of the above tests, replace the harness.**

5. With the meter ground lead connected to a vehicle ground, turn the key ON and check for 12V on pin 4 at the black 6-pin connector. Then check for 12V on pin 1 of the white 4-pin connector in the cab.

**NOTE: If battery voltage is missing, repair or replace, as needed.**

6. Check for continuity of ground wire between pin 1 at the black 6-pin connector and pin 4 of the white 4-pin connector in the cab.
7. If the orange CHMSL wire is connected to the brake lighting circuit in the cab of the vehicle, depress the brake pedal and check for 12V on the black 6-pin connector at pin 4.

**NOTE: Not all vehicles will connect in the cab. Some may need to be connected at the rear of the vehicle. Check the body builder's guide pertaining to the make of the vehicle.**

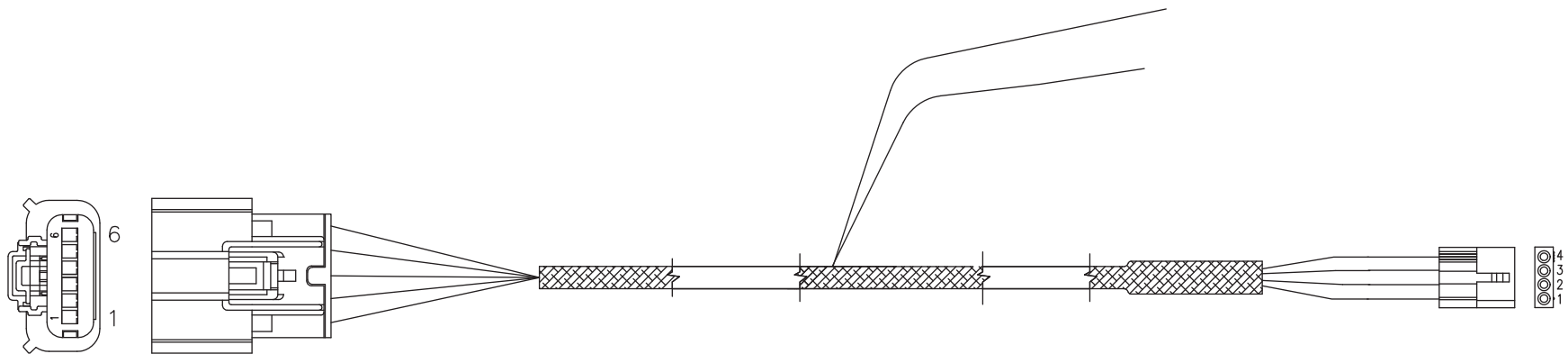

# STEEL HOPPER SPREADERS – TESTING

## Checking Vehicle Spreader Harness

1. Disconnect the vehicle spreader harness from the vehicle control harness at the black 6-pin connector. Disconnect the vehicle spreader harness from the 8-pin spreader harness at the rear of the vehicle. Leave the POSITIVE (+) and NEGATIVE (-) battery leads connected to the battery.
2. Visually inspect the wiring harness for damage.
3. At the 8-pin connector, check for continuity between all pins 3–8. **There should NOT be continuity between any combinations of these wires.**

4. Take the jumper wire and connect it between pins 2 and 3 of the black 6-pin connector. Now connect the meter between pins 6 and 7 of the black 8-pin plug. **The meter should read zero resistance.**

**NOTE: If the harness fails any of the above tests, replace the harness.**

5. With a meter, check for battery voltage at pins 1 and 2 of the 8-pin plug. If the voltage is low, or if no power exists, check for loose or corroded connections at the vehicle battery and at the 100A mega fuse.
6. With the positive lead of the meter connected to pin 1 of the black 8-pin plug, take the black lead and check pin 8 of this plug for battery voltage. Also check pin 1 of the black 6-pin connector for battery voltage.

7. Take the jumper wire and connect it between pins 1 and 3 of the 8-pin plug. Now at the black 6-pin connector, check for battery voltage. Connect the red lead of the tester to pin 5 and the black tester lead to pin 1.
8. To check the license plate light, turn on the parking lights, and check for battery voltage at pin 4.
9. If the orange (Center High Mounted Stop Light) CHMSL wire is connected to the brake lighting circuit at the rear of the vehicle, depress the brake pedal and check for battery voltage at pin 5 of the black 8-pin plug.

**NOTE: Not all vehicles will connect at the rear of the vehicle. Some may need to be connected in the cab. Check the body builder's guide pertaining to the make of the vehicle.**

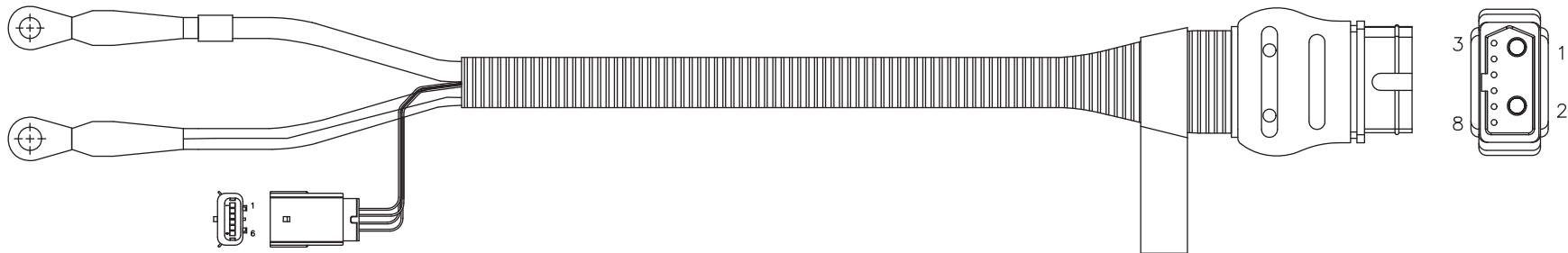

# STEEL HOPPER SPREADERS – TESTING

## Checking Spreader Harness Assembly

1. Disconnect the spreader harness from the vehicle spreader harness and from port B of the spreader module.
2. Visually inspect the wiring harness for damage.
3. At the 8-pin connector check for continuity between all pins 3–8. **There should NOT be continuity between any combinations of these wires.**
4. Check the switched accessory wire for continuity from pin 3 at the 8-pin plug to pin F at the 10-pin connector.
5. Check the battery ground wire for continuity from pin 8 at the 8-pin plug to pin K at the 10-pin connector.

6. Check the orange CHMSL wire for continuity from pin 5 at the 8-pin plug to the orange wire at the CHMSL light.
7. Check the plate light wire for continuity from pin 4 at the 8-pin plug to the brown wire at the plate light.
8. Take the jumper wire and connect it between pins B and C of the black 10-pin connector. Now connect the meter between pins 6 and 7 of the black 8-pin plug. The meter should read continuity.

**NOTE: If the harness fails any of the above tests, replace the harness.**

9. To check the chute present switch, verify that the chute magnet is in place. Connect the black lead of the meter to the NEGATIVE (–) battery wire at the module. Connect the red lead to pin B of the 10-pin connector. With the chute in the closed position there will be continuity. Swing the chute open and continuity will be lost. If there is not continuity with the chute closed, replace the magnetic switch. **Do not probe** the switch connectors. Doing so will damage the contacts.
10. To check the dump switches, connect the black lead of the meter to the black wires on the GND post of the spreader module. Connect the red lead to pin E of the 10-pin connector. Push both dump switches at the same time. There will be continuity. If there is not continuity, disconnect the harness from each of the dump switches. Check each switch for continuity by connecting the meter to each terminal then push the button. If no continuity is found, replace the switch.

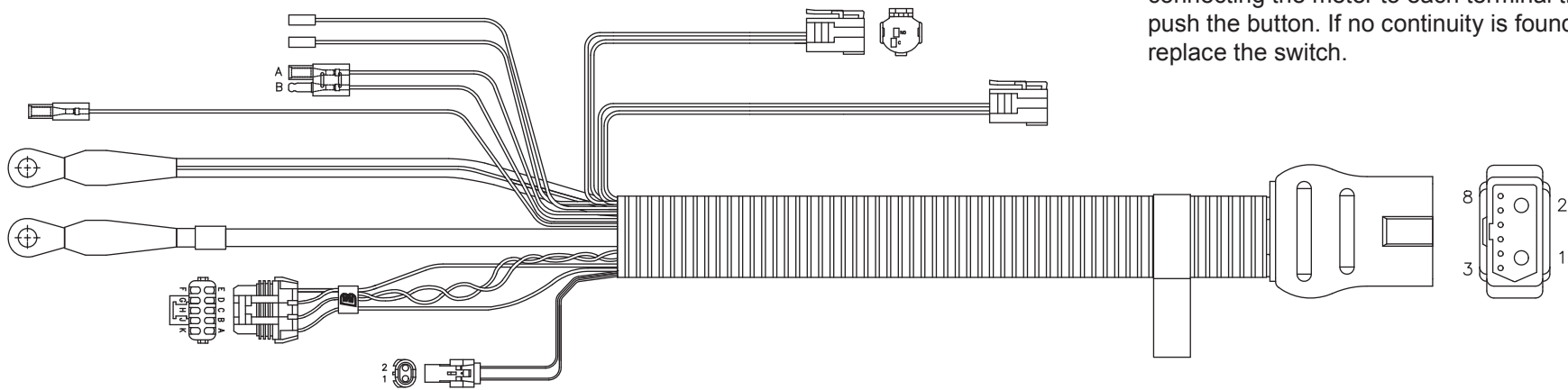

## STEEL HOPPER SPREADERS – TROUBLESHOOTING GUIDE

For a reference table of the cab control error codes, see the Operating the Spreader – Cab Control section of this manual.

Problem	Possible Cause	Suggested Solution
<b>Control not turning on.</b> Ignition and control switches ON; control knob indicator lights not illuminated.	1. Control connector plug is loose.	1. Check plug connection at cab control.
	2. Switched accessory connection is poor or faulty.	2a. Check for low battery. 2b. Check switched accessory connection.
	3. Vehicle control harness is damaged.	3. Repair or replace damaged wires or harness as required.
<b>Turning control knobs does not change motor speed.</b>	1. Malfunctioning cab control.	1. Replace cab control.
	2. Malfunctioning spreader module.	2. Replace spreader module.
<b>Spreader does not operate.</b>	1. Overloaded condition is causing over-current protection to activate.	1. Reset cab control by pressing the ON/OFF switch.
	2. Wire harness is damaged or has an open circuit between cab control and spreader.	2a. Check plug connections at cab control and spreader. 2b. Check wire connections at spreader motor and at vehicle battery: disconnect motor leads, turn Material Width and Material Flow knobs to maximum, and check for voltage at motor leads. 2c. Repair or replace damaged wires and connectors. 2d. Check the 100A in-line fuse on the 22" red cable. Replace if necessary.
<b>Spinner does not turn.</b> Motor is running.	<b>Unplug the spreader harness and tag out, if required, before performing any of the following repairs.</b>	
	1. Obstruction is preventing rotation.	1. Clear obstruction.
	2. Drive belt is loose or damaged.	2. Adjust the tension or replace the belt if worn or damaged.
	3. Motor pulley not secured to motor shaft.	3. Tighten the pulley set screw or replace the pulley if damaged.
	4. Spinner pulley is not secured to spinner shaft.	4. Tighten the pulley set screw or replace the pulley if damaged.
	5. Spinner shaft bearings are dry or seized.	5. Grease or replace bearings.

41

*Table continues on next page.*



# STEEL HOPPER SPREADERS – TROUBLESHOOTING GUIDE

Steel Hopper Spreaders Troubleshooting (continued)

Problem	Possible Cause		Suggested Solution
<b>Conveyor chain not moving.</b> Spinner is turning.	<b>Unplug the spreader harness and tag out, if required, before performing any of the following repairs.</b>		
	1. Obstruction is preventing rotation.	1. Clear obstruction.	
	2. Gear box is damaged.	2. Replace gear box if output shaft does not turn when motor shaft turns.	
	3. Conveyor sprockets are not secured to shafts.	3. Replace or tighten set screws. Replace shafts or sprockets if damaged.	
	4. Conveyor pintle chain is loose or damaged.	4. Adjust pintle chain tension. Replace pintle chain if damaged.	
	5. Conveyor pintle chain is not aligned.	5. Align pintle chain to ride centered on rollers.	
<b>Material in hopper does not flow.</b> Conveyor pintle chain and spinner are moving.	<b>Unplug the spreader harness and tag out, if required, before performing any of the following repairs.</b>		
	1. Feed gate is closed.	1. Open feed gate fully, then adjust to desired opening size.	
	2. Obstruction in hopper.	2. Clear obstruction.	
	3. Material bridged.	3. Clear the bridged material.	



# STEEL HOPPER SPREADERS – ELECTRICAL SYSTEM – ELECTRIC MODELS

## WIRING – VEHICLE HARNESS DIAGRAM

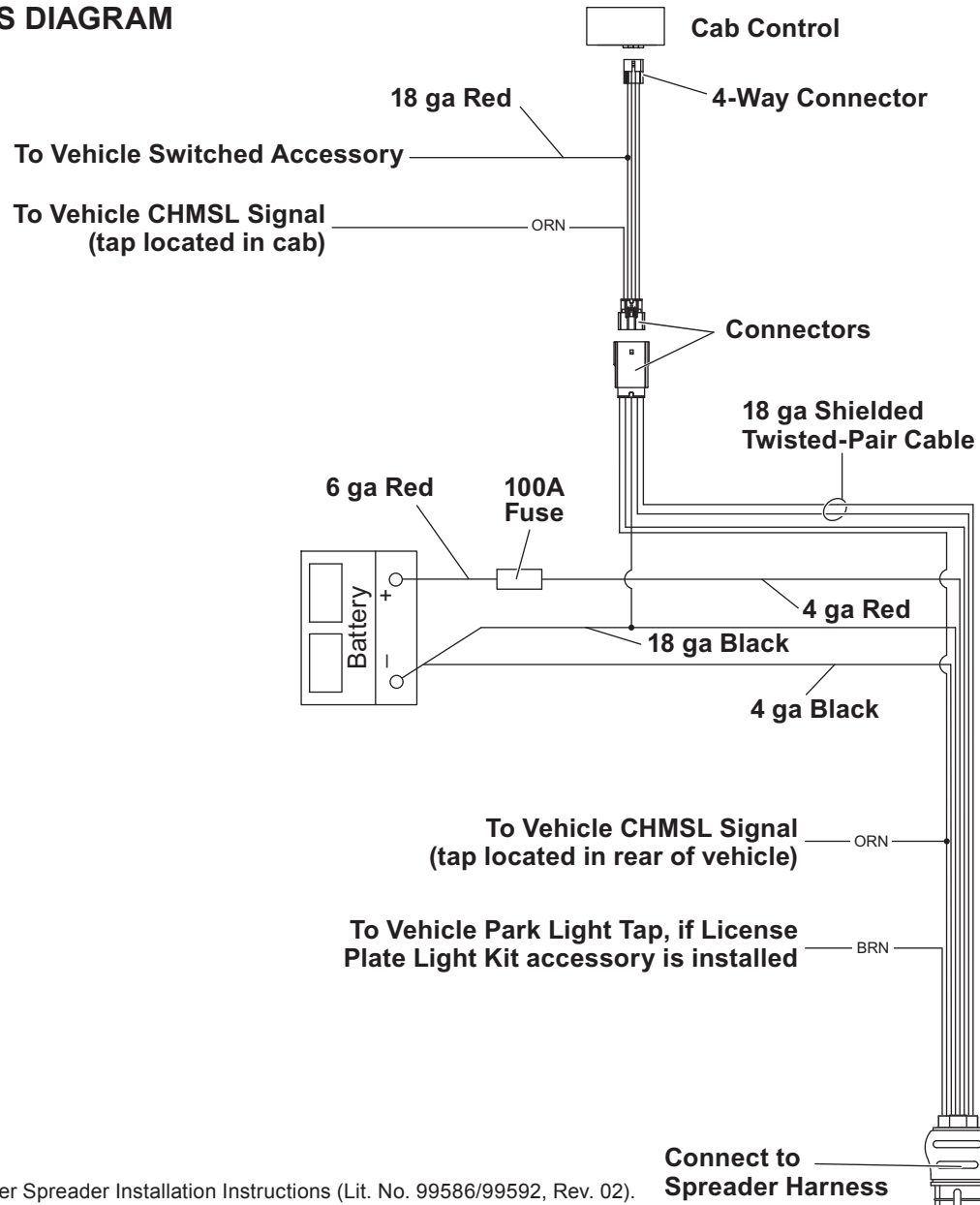

# STEEL HOPPER SPREADERS – ELECTRICAL SYSTEM – ELECTRIC MODELS

## STAINLESS STEEL HOPPER HARNESS/CABLE ASSEMBLIES

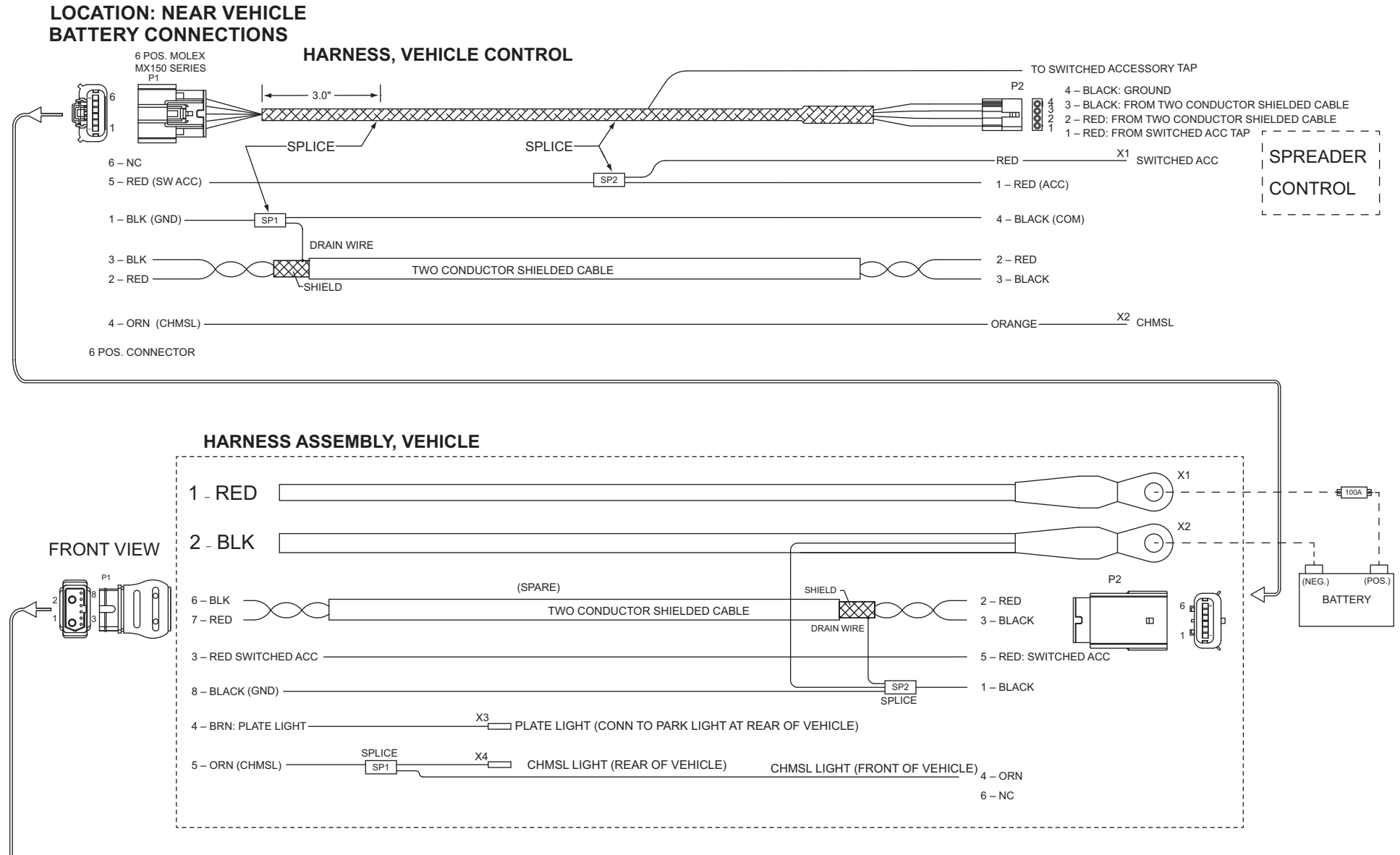

# STEEL HOPPER SPREADERS – ELECTRICAL SYSTEM – ELECTRIC MODELS

## STAINLESS STEEL HOPPER HARNESS/CABLE ASSEMBLIES (continued)

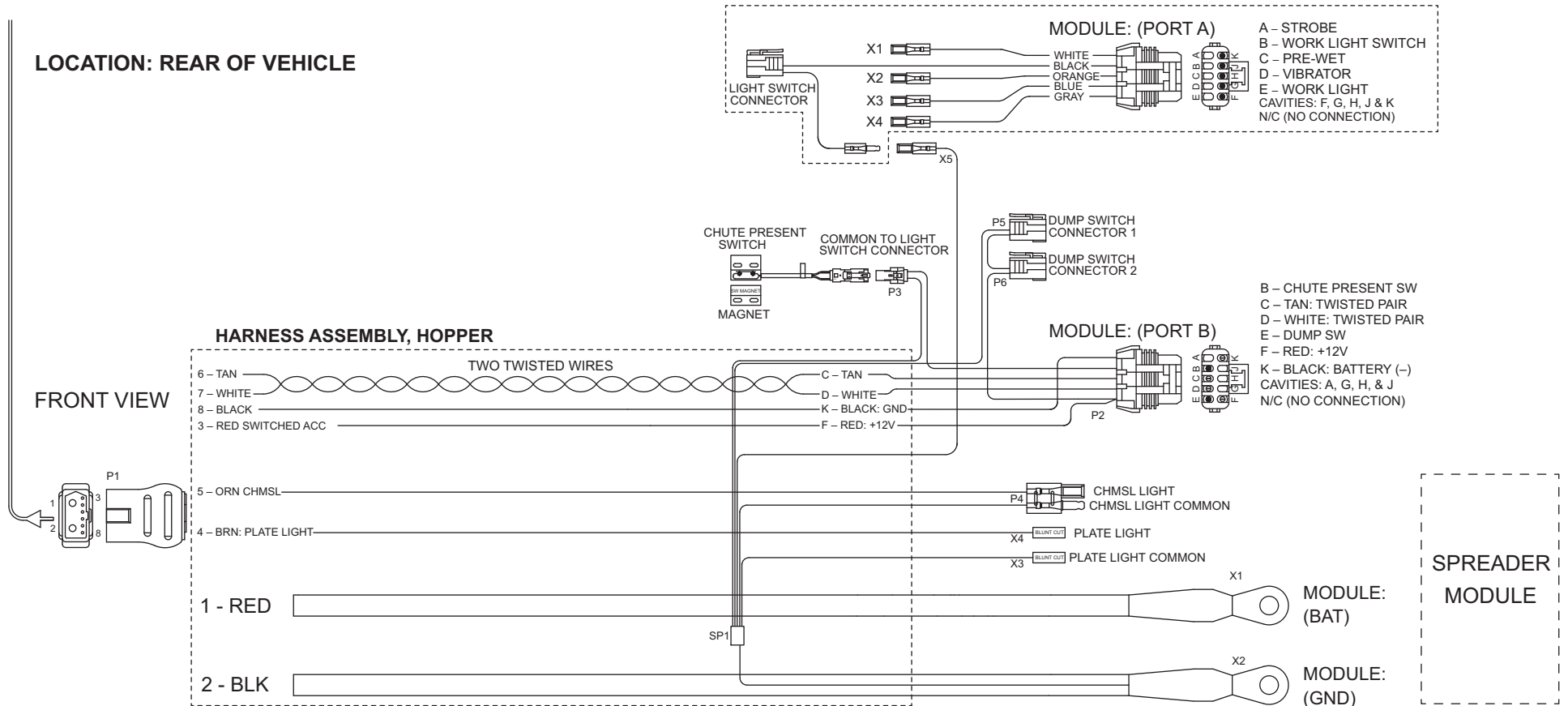

# STEEL HOPPER SPREADERS – ELECTRICAL SYSTEM – ELECTRIC MODELS

## HARNESSING COMPONENTS

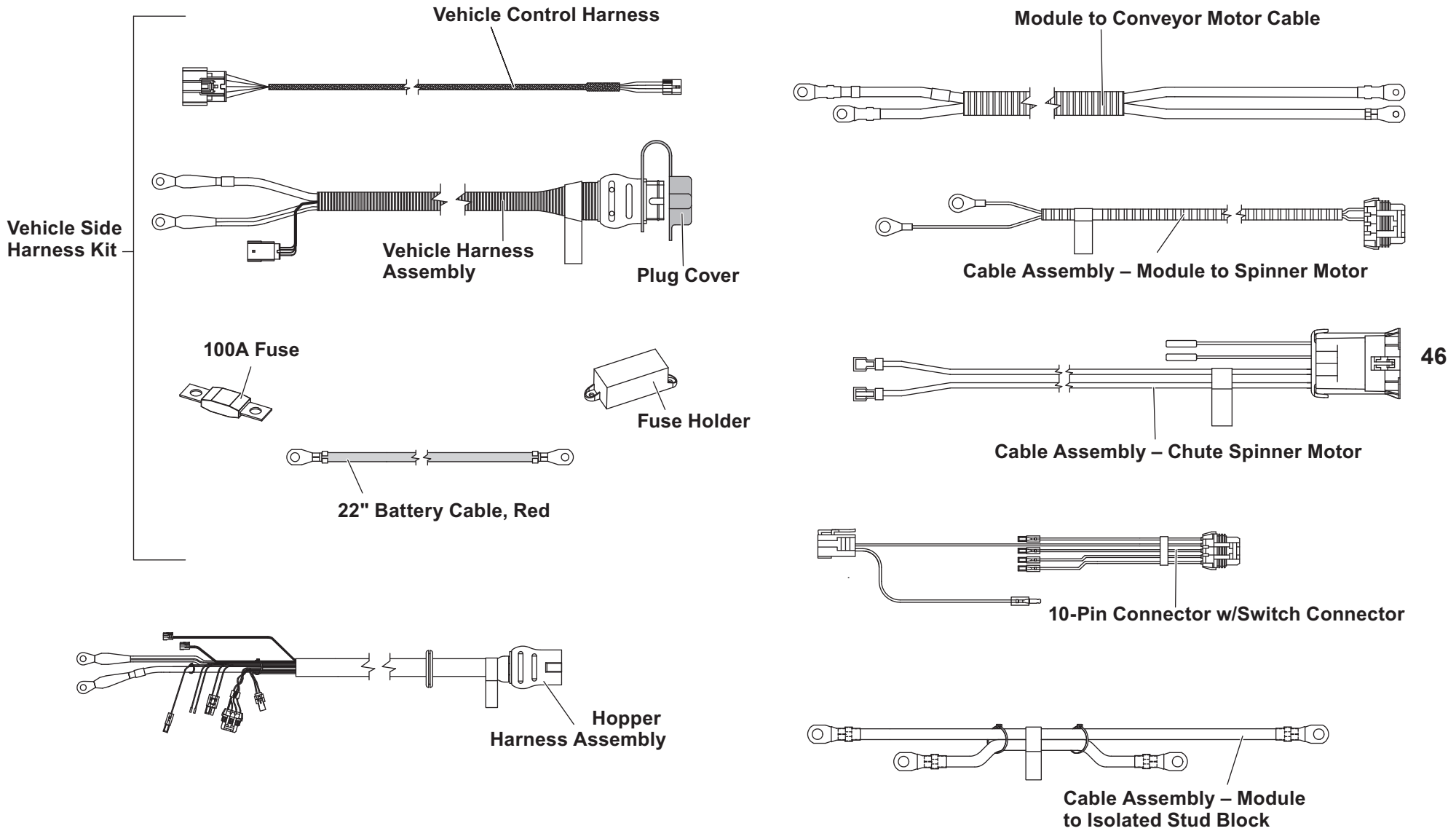

Excerpts taken from STEEL-CASTER™ Hopper Spreader w/Electric Motors Parts List (Lit. No. 99592, Rev. 02).

# STEEL HOPPER SPREADERS – RELAY KIT INSTALLATION – GAS

## RELAY KIT INSTALLATION INSTRUCTIONS

**NOTE: The Relay Kit (PN 48627) is used to prevent voltage spikes caused by the gas hopper control.**

- Trim the red wire from the control as needed and crimp on the supplied insulated terminal. Connect the wire to relay terminal 87.

### CAUTION

Connect green wire from ground to relay terminal 85. Reversing this connection will damage the internal relay diode, causing the relay to be inoperable.

- Connect the supplied green wire to relay terminal 85. This wire should be connected to vehicle ground.
- Connect the supplied red jumper wires to relay terminals 30 and 86.
- The red wire connected to relay terminal 30 should be connected to an under-dash 12V source (battery voltage) capable of supplying 15A.

If needed, extend the wire to reach the POSITIVE (+) terminal of the battery. The extended wire will need to be protected by a 20A in-line fuse (not supplied).

- The red wire connected to relay terminal 86 should be connected to a switched 12V source (+12V when vehicle ignition is ON, 0V when vehicle ignition is OFF).

**NOTE: When connecting to a fused vehicle switched 12V source, always connect to the "load" side (protected side) of the fuse (i.e., so there will be no power if the fuse opens).**

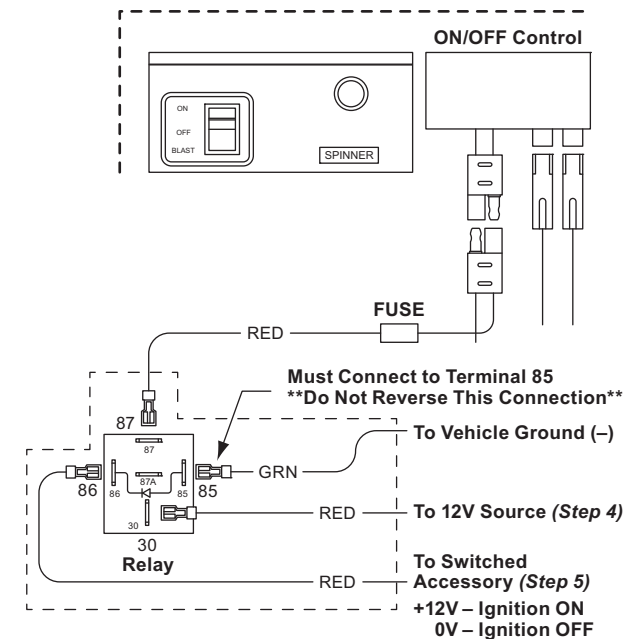
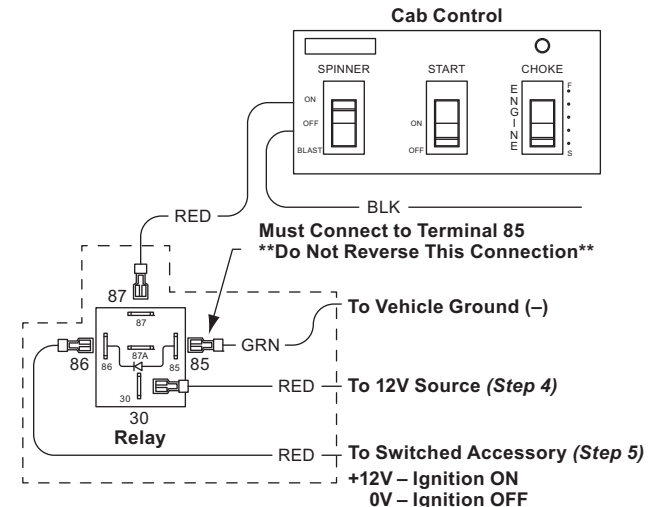
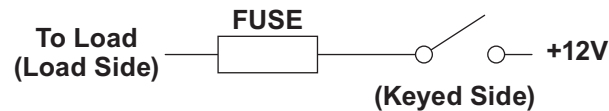

Excerpts taken from 48627 Relay Kit Installation Instructions (Lit. No. 48626, Rev. 00).

# STEEL HOPPER SPREADERS – ELECTRICAL: CAB CONTROL WIRING INSTRUCTIONS – GAS

## 11-PIN HARNESS

### Cab Control Wiring Diagram – 11-Pin Harness Two-Light Control (Engine ON & Choke Lights)

**⚠ WARNING**  
ON wire connections are engine specific.

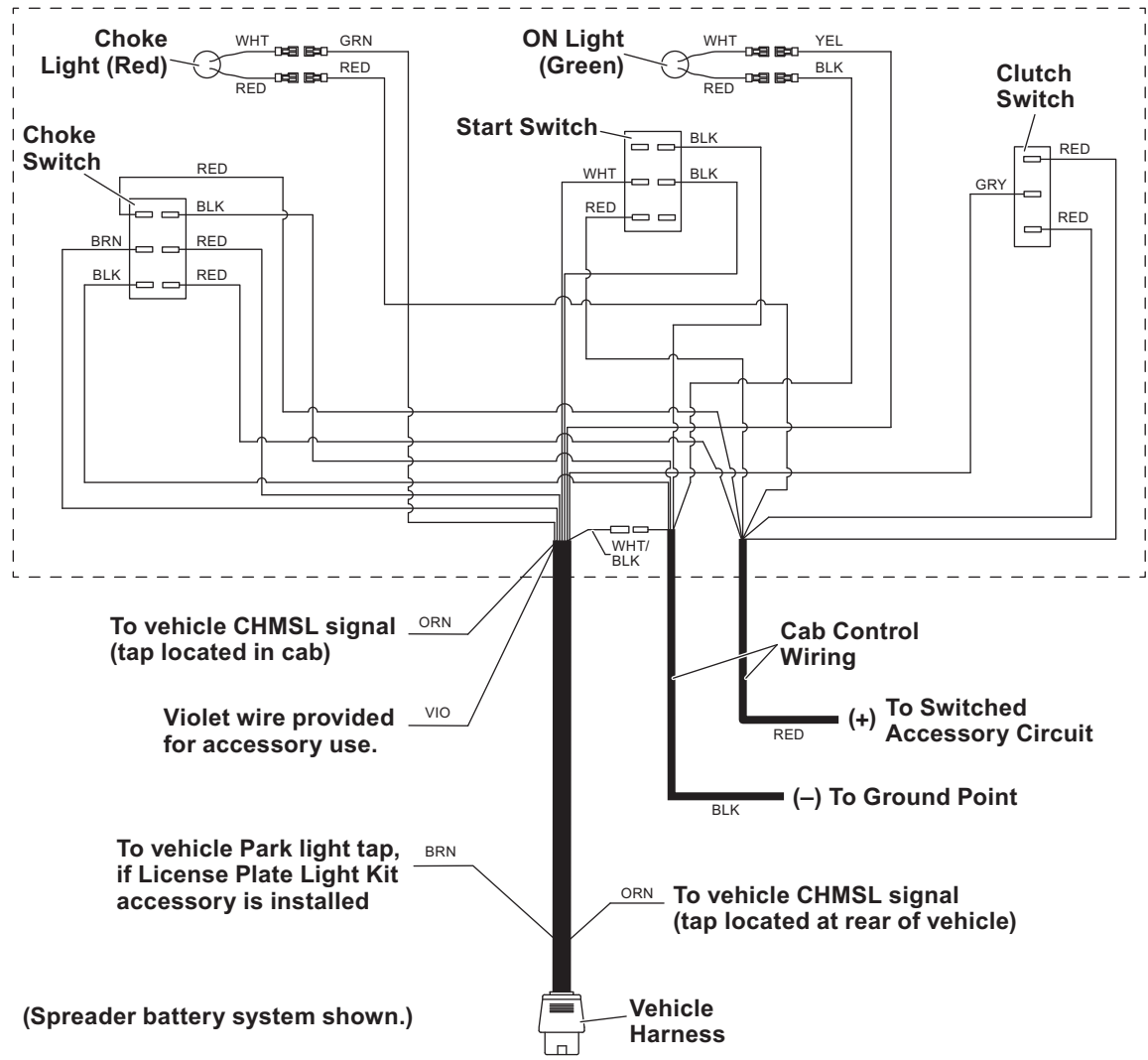

### 11-Pin Harness — Wire Locations and Colors

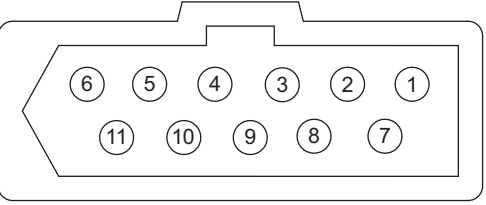

1. Black
2. Brown
3. Red
4. Orange
5. Yellow
6. Green
7. Blue
8. Violet
9. Gray
10. White
11. White/Black

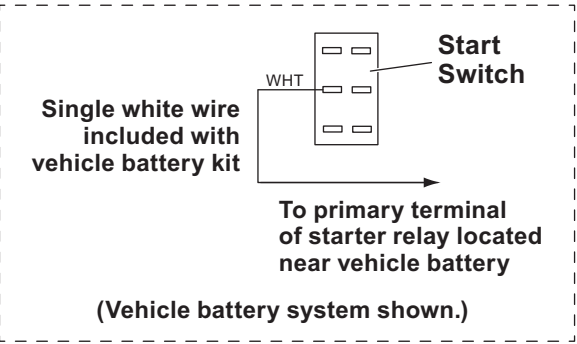

Excerpts taken from Hopper Spreader Cab Control and Electrical Components Installation Instructions (Lit. No. 96200, Rev. 11).

## STEEL HOPPER SPREADERS – ELECTRICAL: CAB CONTROL WIRING INSTRUCTIONS – GAS

---

- **Orange** – Loop it around and pass it out the large rubber grommet in the back of the cab control.
- **Gray** – Connect to the middle terminal of the CLUTCH switch.
- **Black** – Connect to the middle right terminal (as viewed from rear) of the START switch.
- **White – For spreader battery system,** connect to the middle left terminal (as viewed from the rear) of the START switch.

**For vehicle battery system,** the white wire from the vehicle harness will not be used. Connect the white relay wire (supplied with the vehicle battery kit) from the starter relay to the middle left terminal (as viewed from the rear) of the START switch. Also refer to the Vehicle Battery Kit Installation Instructions included with the vehicle battery kit.

- **Brown** – Connect to the middle left terminal (as viewed from the rear) of the CHOKE switch.
- **Red** – Connect to the middle right terminal (as viewed from the rear) of the CHOKE switch.
- **Green** – Connect to the white wire of the choke light (red light).
- **White/Black** – Connect to the black cab control ground wire.
- **Violet** – Pass back out of the control. This wire is provided for accessory use.

### Spreader with Briggs & Stratton Engine

- **Yellow** – Connect to the white wire of the engine ON light (green light).
- **Black from cab control ground harness** – Connect to the red wire of the engine ON light.

### Spreader with Honda Engine

- **Yellow** – Connect to the red wire of the engine ON light (green light).
  - **Black from cab control ground harness** – Connect to the white wire of the engine ON light.
1. Connect the black wire from the cab control to a known ground on the vehicle.
  2. Connect the red (power) wire to an accessory wire/terminal that is controlled by the vehicle's ignition switch.
  3. Replace the cab control cover.
  4. Install the cab control in the cab of the truck, following the instructions packed with the control.





# STEEL HOPPER SPREADERS – ELECTRICAL SYSTEM – BRIGGS & STRATTON W/VEHICLE BATTERY

## BRIGGS & STRATTON ELECTRIC START WITH VEHICLE BATTERY

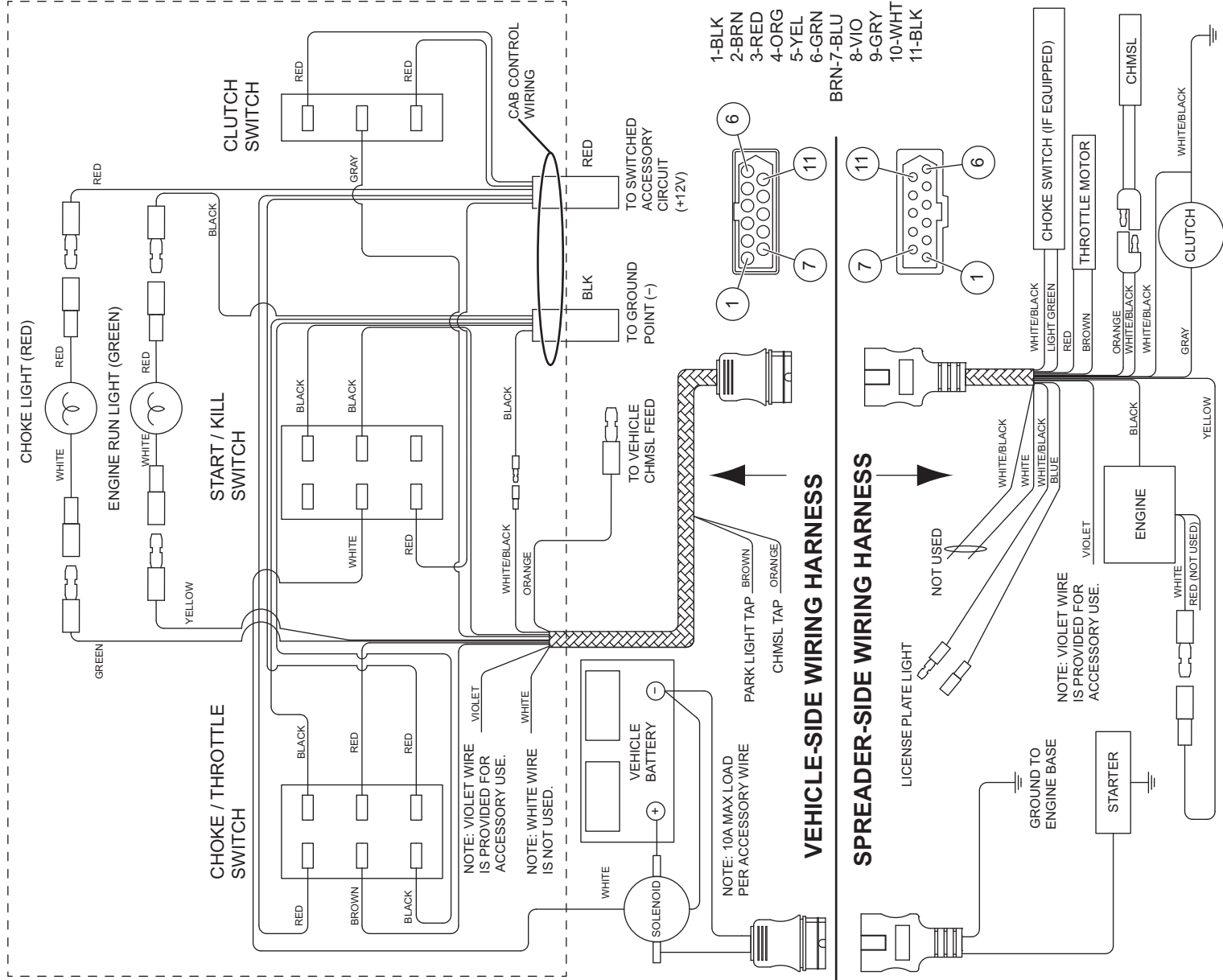

# STEEL HOPPER SPREADERS – ELECTRICAL SYSTEM – HONDA W/SPREADER BATTERY

## HONDA ELECTRIC START WITH SPREADER BATTERY

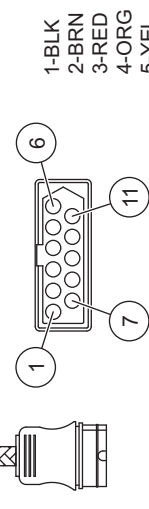
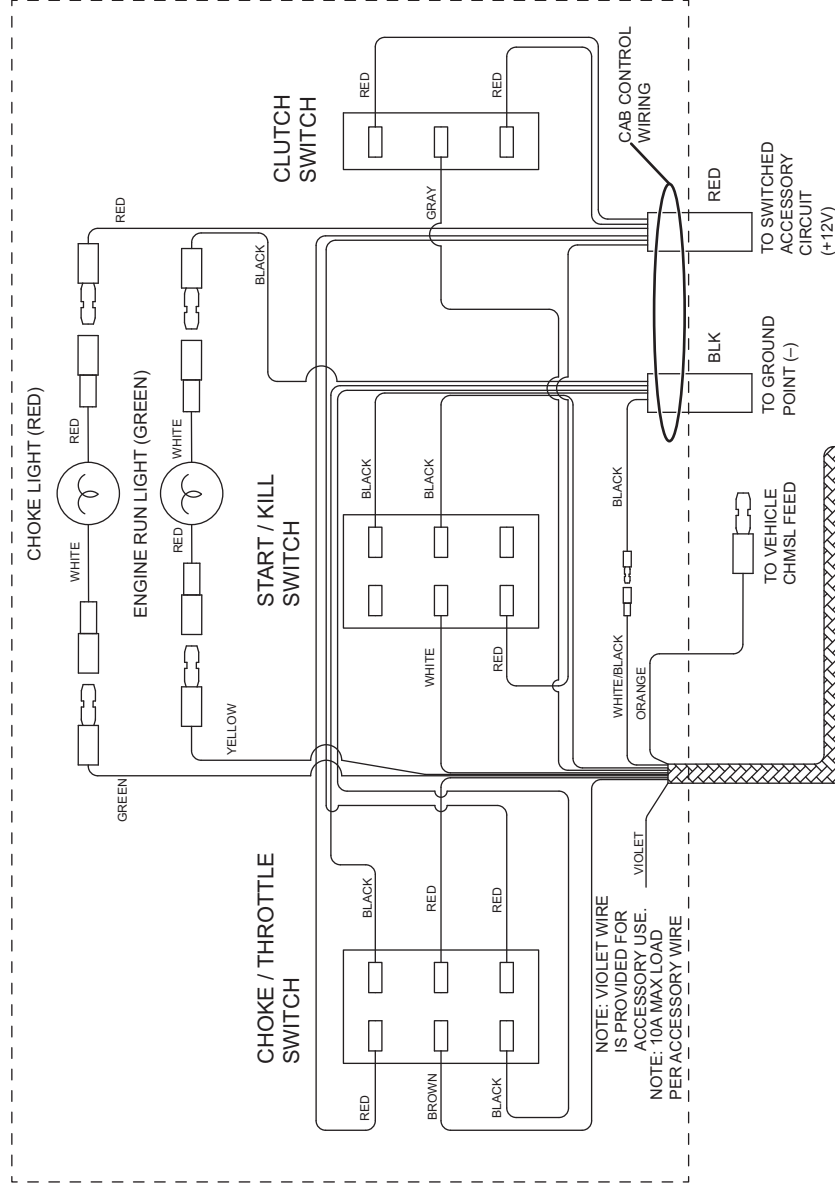

## VEHICLE-SIDE WIRING HARNESS

### SPREADER-SIDE WIRING HARNESS

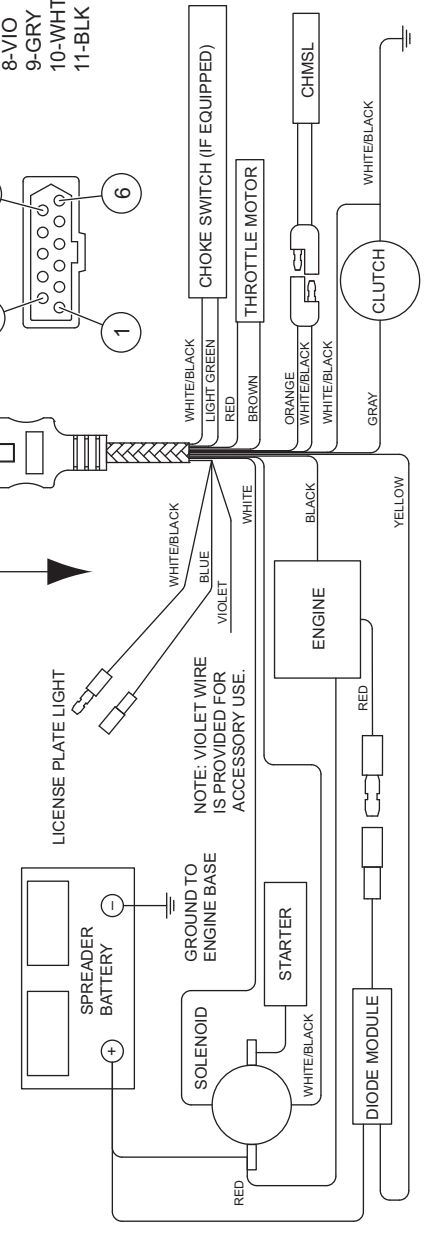

# STEEL HOPPER SPREADERS – ELECTRICAL SYSTEM – HONDA W/VEHICLE BATTERY

## HONDA ELECTRIC START WITH VEHICLE BATTERY

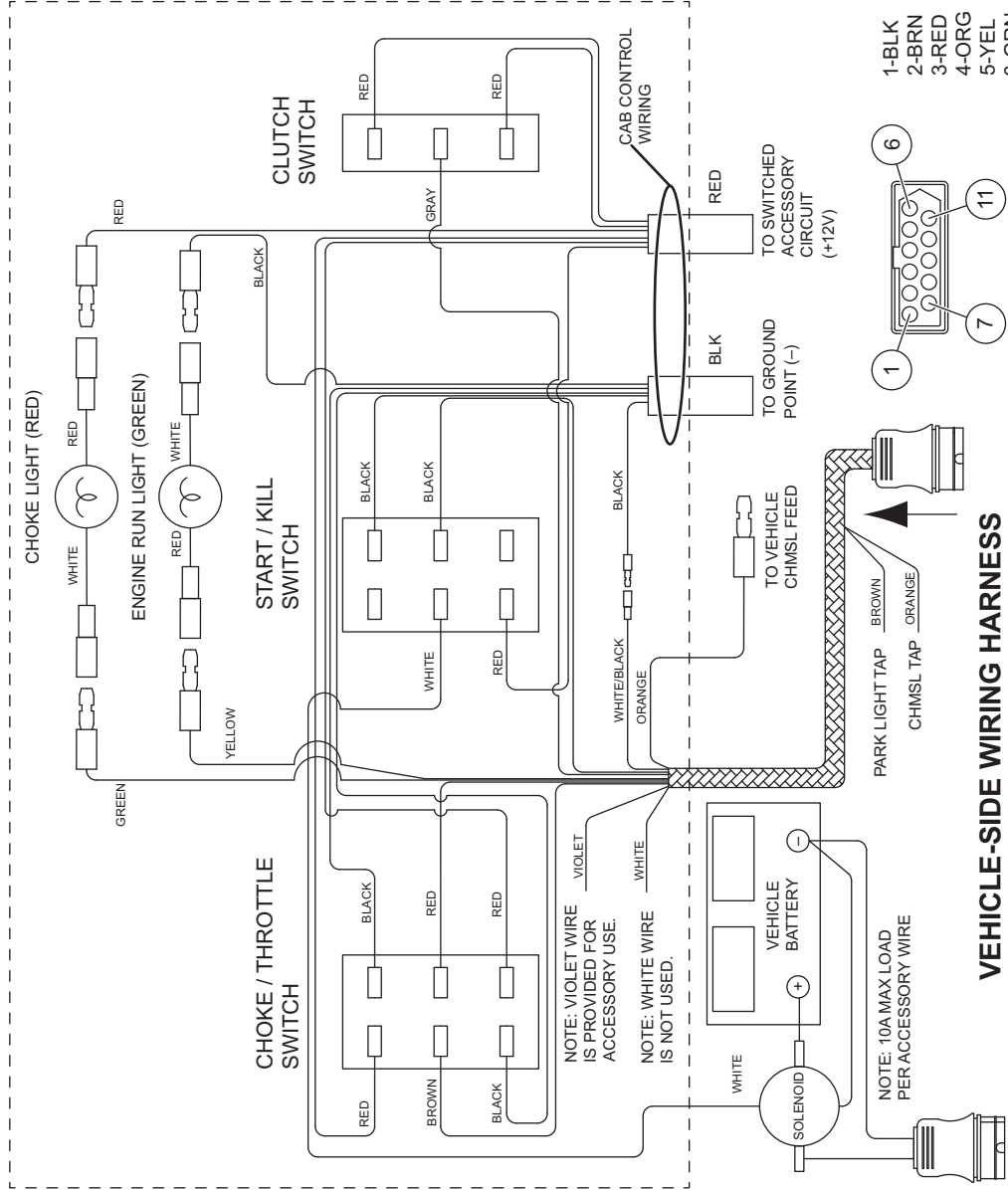

## VEHICLE-SIDE WIRING HARNESS

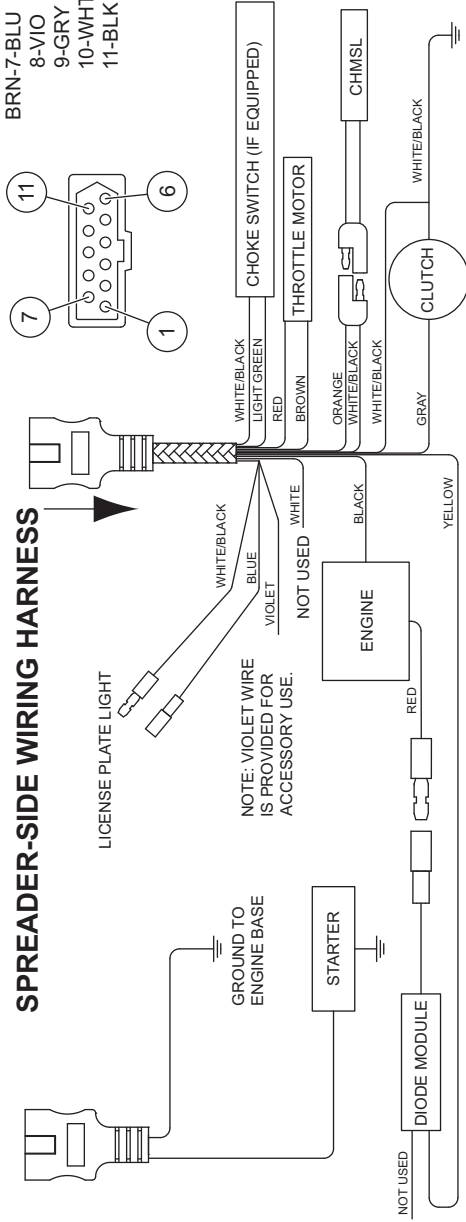

# STEEL HOPPER SPREADERS – TROUBLESHOOTING GUIDE

## ELECTRIC CLUTCH

Condition	Possible Cause	Action
<b>Clutch will not engage.</b>	1. No ground to clutch.	1. Check for ground at clutch ground wire.
	2. No power to clutch.	2a. With the clutch switch in the "ON" position, check gray wire at clutch for battery voltage. 2b. Check the 11-pin vehicle harness for battery voltage on pin 9. 2c. Check clutch switch in cab control for battery voltage input and output with the switch in the "ON" position. 2d. Check clutch for continuity between two wires (approx. 3–4 ohm).
<b>Clutch slips.</b>	1. Low voltage.	1. Check all harnesses for voltage drop.
	2. Oil, grease, dirt, or rust in between or on the face of field and rotor.	2. Disassemble and clean both surfaces.
	3. Broken springs in rotor causing air gap.	3. Replace clutch.
<b>Clutch will not disengage.</b>	1. Seized rotor bearing.	1. Replace clutch.
	2. Galling between stator and rotor.	2. Replace clutch.
	3. Broken springs in rotor.	3. Replace clutch.
	4. Rust and/or corrosion build-up under leaf springs pushing stator and rotor together.	4. Replace clutch.
	5. Constant power to clutch.	5. Replace clutch switch.

# STEEL HOPPER SPREADERS – GAS – ELECTRIC CLUTCH

## REMOVING & INSTALLING ELECTRIC CLUTCH

### ⚠ WARNING

Gasoline is highly flammable and gasoline vapor is explosive. Never smoke while working on vehicle. Keep all open flames away from gasoline tank and lines. Wipe up any spilled gasoline immediately.

### Tools Needed:

- Three-jaw gear puller
- Torch for heating/cutting

### Removing Clutch

1. Disconnect battery power from spreader.
2. Disconnect spark plug wire and isolate from spark plug.
3. Disconnect the clutch power and ground wires.
4. Loosen the two set screws of the 16-tooth sprocket that runs the spinner. Remove the sprocket (puller may be required).
5. Remove the #40 chain from the engine sprocket to the clutch sprocket by loosening the four bolts that hold the engine base and sliding it toward the clutch assembly.
6. Remove the three 5/16"-18 x 3/4" cap screws and lock washers that hold the 52-tooth clutch sprocket in place.
7. Remove the two 1/4" x 1-1/4" cap screws that anchor the torque tab of the clutch.

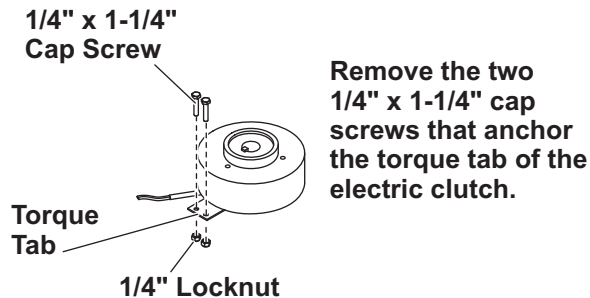

8. Remove the rotor part of the clutch assembly, then remove the armature (puller may be required).

### Installing Electric Clutch

1. Before installing the clutch, inspect all parts that are to be reused for wear and/or damage. Replace worn or damaged parts as needed.
2. Make sure that the input shaft of the gear box is free of any nicks, burrs, rust, and corrosion that may prevent the clutch assembly from sliding onto the shaft. Clean and/or file as needed.
3. Install the key, making sure that it is in the correct location and is not too high for the bearing race. Some races are not the same depth and may have a step.
4. Apply an anti-seize coating to the gear box input shaft. Line up the keyway and slide the armature assembly down the shaft until it is fully seated on the step of the input shaft.

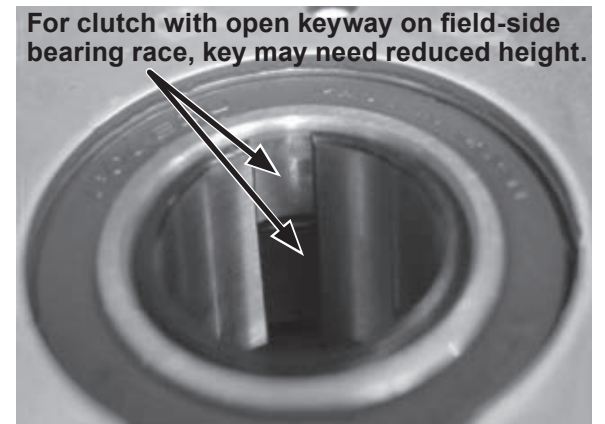

5. Reapply the anti-seize coating to the gear box input shaft. Line up the keyway and slide the stator down until the bearing inner race bottoms out against the armature assembly. There will be a slight air gap between the two parts.
6. Anchor the torque tab using two 1/4" x 1-1/4" cap screws.

**NOTE: Use bolts that have a shoulder that will NOT allow you to fully tighten the bolts. Not allowing the torque tab to float will cause the field bearing to fail.**

7. Connect the power and ground wires to the clutch.
8. Install the 52-tooth clutch mounted sprocket using three 5/16"-18 x 3/4" cap screws and lock washers.
9. Adjust the 12-tooth engine mounted drive sprocket up or down so that it is level with the 52-tooth sprocket.

# STEEL HOPPER SPREADERS – GAS – ELECTRIC CLUTCH

## Installing Electric Clutch (cont.)

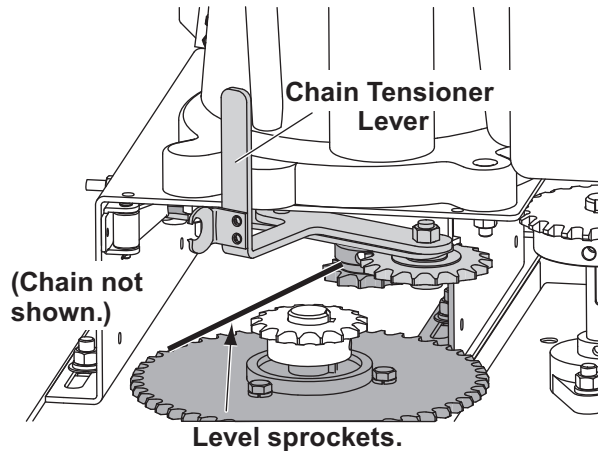

10. Install the #40 chain from the engine sprocket to the clutch sprocket by loosening the four bolts that hold the engine base. Slide it toward the clutch assembly. Install the chain and slide the base away from the clutch to tighten the chain.

11. Do NOT overtighten the chain. There should be 1/4" deflection midway between the sprockets. Tighten the four engine base bolts.

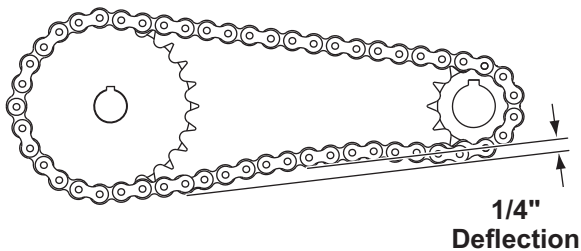

12. Install the 16-tooth sprocket that runs the spinner. Tighten both set screws.

13. Using a straight edge, check the alignment of the spinner shaft and spinner drive sprockets.

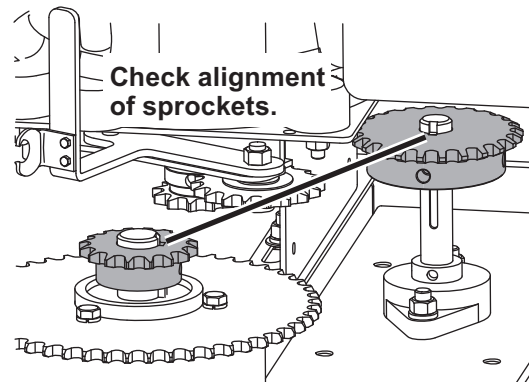

14. To adjust sprocket alignment, loosen the spinner sprocket set screw, adjust the sprocket position up or down as required, and retighten the set screw.

15. Install the drive chain over the spinner shaft and spinner drive sprockets.

### Adjust Spinner Drive Chain Tension

1. Position the tensioner so it is fully extended, with the idler sprocket engaged with the chute drive chain.
2. Loosen the pivot bolt and nut.
3. Slide the tensioner toward the chain until the chain is tight.
4. Tighten the tensioner pivot bolt nut.
5. Loosen the tensioner adjustment bolt jam nut and advance the adjustment bolt until it contacts the tensioner pivot bolt nut. This will keep the pivot bolt from moving.

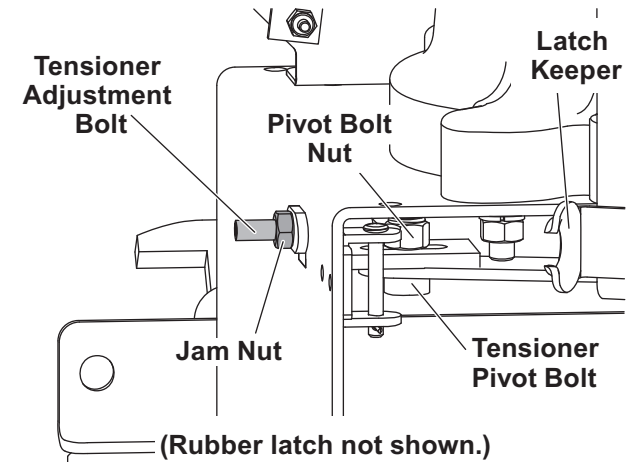

6. Tighten the tensioner adjustment bolt jam nut.

7. Check the chain tension. Correct tension allows the chain to move 1/4" when pressed midway between the sprockets. To adjust the tension, repeat Steps 2–6 as required.

8. Tighten the tensioner pivot bolt nut to 30 ft-lb. Tighten the tensioner adjustment bolt jam nut.

9. Hook the rubber latch into the latch keeper on the tensioner lever.

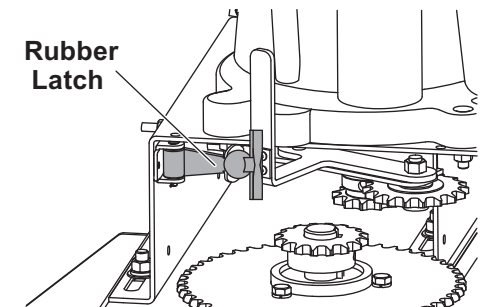

10. Close the engine cover and secure the back latches. Close and latch the access door.

Excerpts taken from STEEL-CASTER™ Steel Hopper Spreader Installation Instructions (Lit. No. 99587/99593, Rev. 03).

# STEEL HOPPER SPREADERS – ELECTRIC

---

## SPINNER MOTOR REPLACEMENT

1. Disconnect the chute electrical harness and remove the chute from the spreader.
2. Remove the chute cover plate that covers the motor and pulleys.
3. Remove the spinner belt from the spinner and motor pulleys by swinging the motor towards the spinner pulley.
8. Reinstall the spinner belt over both the motor and shaft pulleys. Confirm that the pulleys are aligned with each other and that the belt is running true. If adjustment is needed, loosen the set screw on the motor pulley and adjust the pulley up or down as required. Retighten the set screw.
9. Reinstall the chute cover plate.

---

**NOTE: The spinner motor mount is spring loaded.**

---

4. **If the motor is in need of replacement:** Disconnect the wire harness at the spade connectors. Remove the two #10-32 locknuts and washers that attach the motor to the tensioner plate.
5. Pull the motor with the pulley attached out of the plate.
6. Reinstall the new motor with the pulley attached using two #10-32 locknuts and washers. Reconnect the harness to the motor.
7. Turn the spinner shaft by hand, ensuring that it moves freely. Check for looseness in the shaft bearings. Repair as needed. Grease both upper and lower shaft bearings.

10. Reinstall the chute on the spreader.
11. **Run the spreader to verify correct operation. Pay attention to the spinner. It should turn in a clockwise rotation. If not, swap the spade connections at motor.**

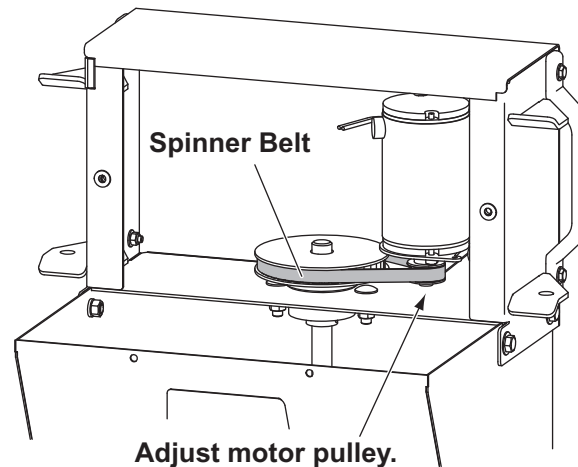



# STEEL HOPPER SPREADERS – ELECTRIC: GEAR BOX ASSEMBLY – FLEET FLEX SYSTEM

## REPLACING GEAR BOX ON HOPPERS WITH FLEET FLEX SYSTEM

**NOTE:** Disconnect the spreader electrical harness from the vehicle harness before making any repairs to the unit.

**NOTE:** Spreader gear box is sealed and not serviceable.

## STAINLESS STEEL HOPPER SPREADERS

### Removing Gear Box Assembly

1. Disconnect the power and ground wires from the conveyor motor. Remove the motor from the primary gear box.
2. Loosen the fasteners on each of the idler shaft bearings located at the front of the spreader on both sides of the sill.
3. Loosen the jam nuts on the take-up bolts. Back off the bolts enough to allow the idler shaft to slide back evenly. This will allow the conveyor chain to slacken.
4. At the secondary gear box (lower) remove the black plastic cover exposing the end of the drive shaft. Remove the 1" retaining ring (e-clip) from the end of the drive shaft.
5. Remove the four fasteners that mount the gear box bracket to the electric power group mount.
6. Pull the gear box assembly out. The drive shaft will remain in place. You may need to lightly tap on the end of the shaft to get it started. Be careful not to damage the end of the shaft.

7. Remove the four bolts that mount the gear box assembly to the mounting bracket.

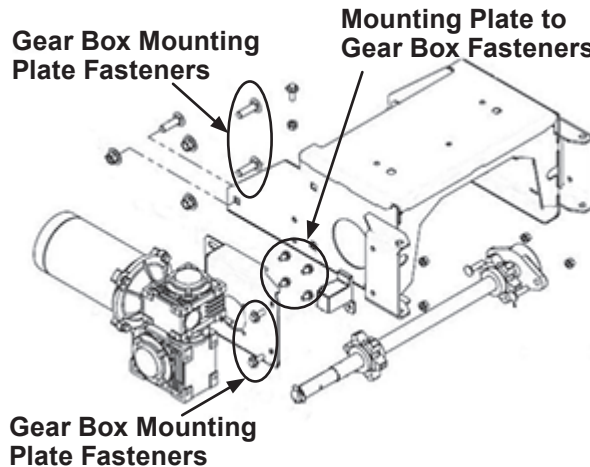

### Installing Gear Box

1. Mount the gear box assembly to the gear box mounting bracket using four M8-1.25 x 16 mm cap screws with lock washers.
2. Coat the drive shaft with an anti-seize material. Line up the keyways and slide the gear box assembly onto the drive shaft. To aid in aligning the keyways, turn the input shaft of the primary gear box.
3. Using two 3/8"-16 x 1" cap screws and two 1/2"-13 x 1-3/4" carriage bolts with nuts, flat washers, and lock washers, as needed, mount the gear box bracket to the electric power group mount.
4. Install the 1" retaining ring (e-clip) on end of drive shaft and reinstall the cover.

5. Install the motor to the gear box assembly using four 3/8"-16 x 3/4" cap screws with lock washers.
6. Connect the power and ground wires to the motor.
7. Tighten the take-up bolts evenly from side to side until the conveyor chain is visible through the chain tension port. You should be able to lift up the chain 1"-3" at approximately 20"-24" from the rear of the spreader.

**NOTE:** Adjusting the conveyor chain too tight will increase amperage draw.

8. Once the correct chain tension has been achieved, tighten the four bearing mounting bolts.

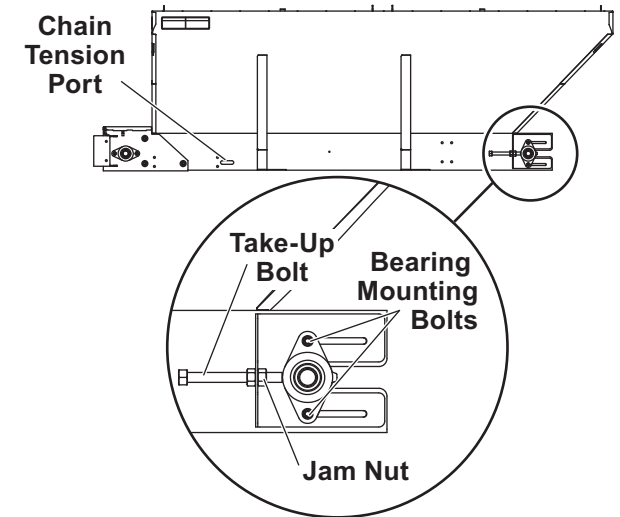

9. Run the spreader to verify the conveyor chain tension and alignment, playing close attention to the conveyor chain direction. If the conveyor is turning in the wrong direction, swap the power and ground wires to change the direction.



# STEEL HOPPER SPREADERS – GAS & HYDRAULIC: GEAR BOX REPLACEMENT

---

## REPLACING THE GEAR BOX

Disconnect and isolate the spark plug wire, electrical connections, or hydraulic lines as applicable.

---

**NOTE: Inspect spreader for any kind of sill damage that may affect repairs.**

---

### Loosen the Conveyor Chain

1. Locate the master link in the conveyor chain. Rotate the chain until the master link is at the drive sprockets.
2. Loosen the fasteners on each of the idler shaft bearings, located at the front of spreader on both sides of the sill.
3. Loosen the take-up bolts enough to allow the idler shaft to slide back evenly. This will allow the conveyor chain to slacken.
4. Remove the cotter pins from the master link on each side. Pull each link pin out.

---

**NOTE: There may still be some tension on the pins due to the weight of the chain.**

---

### Removing the Clutch

See "Removing Clutch" in the Removing & Installing Electric Clutch section of this manual.

## HYDRAULIC MODELS

1. Remove the covers from the hydraulic motor mount. Remove the lower cotter pin and clevis pin from the coupler used to attach the hydraulic motor to the input shaft of the gear box.
2. Remove the two 3/8"-16 x 1-1/2" carriage bolts that hold the end bearing. Remove the four 1/2" button head bolts that hold the gear box. Removing these fasteners will allow the gear box assembly to drop out.

## Installing the Gear Box Assembly

1. Install the replacement gear box by pushing it up into place and securing it with four 1/2"-13 x 3/4" button head bolts with lock washers. Secure the end bearing using two 3/8"-16 x 1-1/2" carriage bolts.
2. Check the position of both 6-tooth drive sprockets for correct location on the gear box output shaft. Adjust as needed.
3. If not already installed, install the gear case breather.
4. Check oil level. Add oil as needed.
5. Reinstall chain.

# STEEL HOPPER SPREADERS – GAS & HYDRAULIC: GEAR BOX

## SERVICING THE GEAR BOX

### ⚠ CAUTION

Disconnect electric power at spreader electrical wiring harness connection and tag out if required before servicing or performing maintenance.

## LUBRICATION

### ⚠ CAUTION

Over-greasing may cause seal damage. The gear case must be filled to the oil-level plug with Mobil SHC 632, Exxon SHP 320, or equivalent synthetic gear-type lubricant. Keep the breather plug clean.

- Change the chain drive gear case oil once a year. Drain the oil by removing the drain plug at the bottom of the gear case. Refill with Mobil SHC 632, Exxon SHP 320, or equivalent synthetic gear oil. Oil level should be even with the bottom of the fill hole.

## GEAR OIL SPECIFICATION

Use Mobil SHC 632 or Exxon SHP 320 or equivalent.

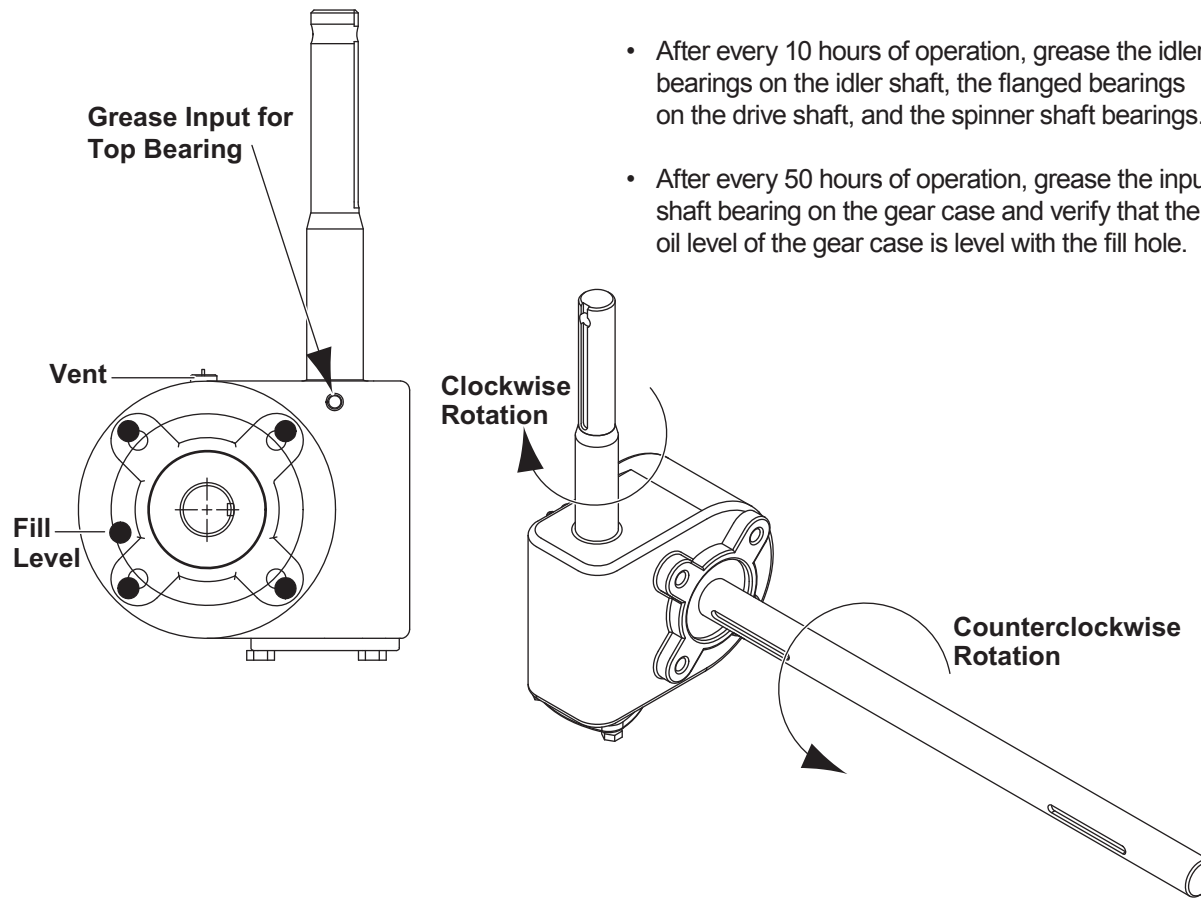
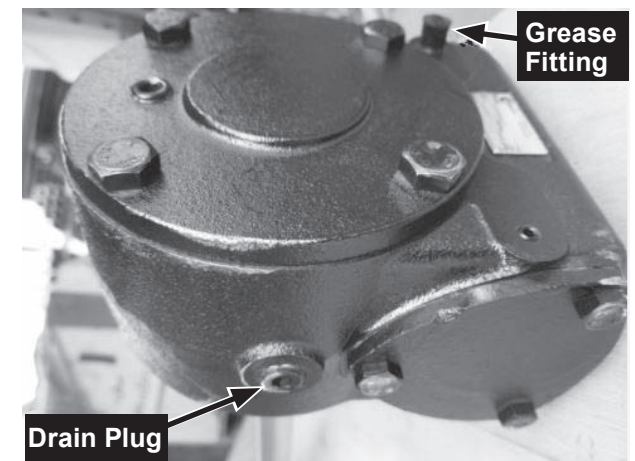
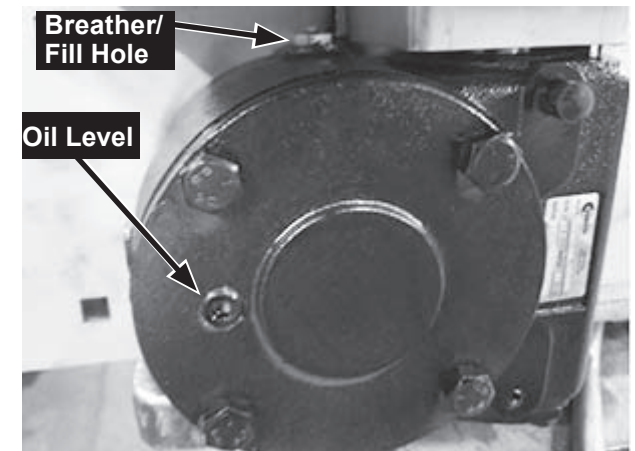

- After every 10 hours of operation, grease the idler bearings on the idler shaft, the flanged bearings on the drive shaft, and the spinner shaft bearings.
- After every 50 hours of operation, grease the input shaft bearing on the gear case and verify that the oil level of the gear case is level with the fill hole.

# STEEL HOPPER SPREADERS – GAS, ELECTRIC & HYDRAULIC – CONVEYOR CHAIN: FLEET FLEX SYSTEM

## REPLACING THE CONVEYOR CHAIN

**NOTE: For Gas Models: Remove the spark plug wire and isolate. For Electric Models: Disconnect electrical connections. For Hydraulic Models: Disconnect hydraulic hoses.**

### Removing the Conveyor Chain

1. Locate the master link in the conveyor chain. Rotate the chain until the master link is at the drive sprockets.
2. Loosen the fasteners on each of the idler shaft bearings located at the front of the spreader on both sides of the sill.
3. Loosen the take-up bolts enough to allow the idler shaft to slide back evenly. This will allow the conveyor chain to slacken.
4. Remove the cotter pins from the master link on each side. Pull each link pin out. There may still be some tension on the pin due to the weight of the chain.
5. Tie a rope to the bottom end of the existing conveyor chain. Holding the top end of the chain, pull the chain out. It may take two people to remove the chain. The rope will feed up through, which will make it much easier for installing the replacement chain.

### Installing the Conveyor Chain

1. Inspect all bearings, idler shaft, etc., before installing the conveyor chain.
2. Starting with the closed link on the end of the chain, tie the end of the rope on the top side of the sill to the chain, making sure that the offset in the crossbar is facing down.

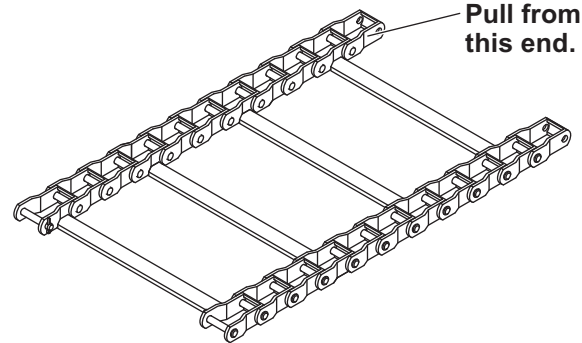

3. Pull on the other end of the rope while guiding the chain up over the drive sprockets. It may take two people to install the chain. Make sure that the chain is positioned correctly into the idler sprockets at the front of the spreader.
4. Once you have pulled the chain into position, install the link pins with cotter pins, separating and bending both legs of the cotter pin.
5. Tighten the take-up bolts evenly from side to side until the conveyor chain is visible through the chain tension port. You should be able to lift up the chain 1"-3" at approximately 20"-24" from the rear of the spreader.

6. Once the correct chain tension has been achieved, tighten the four bearing mounting bolts.

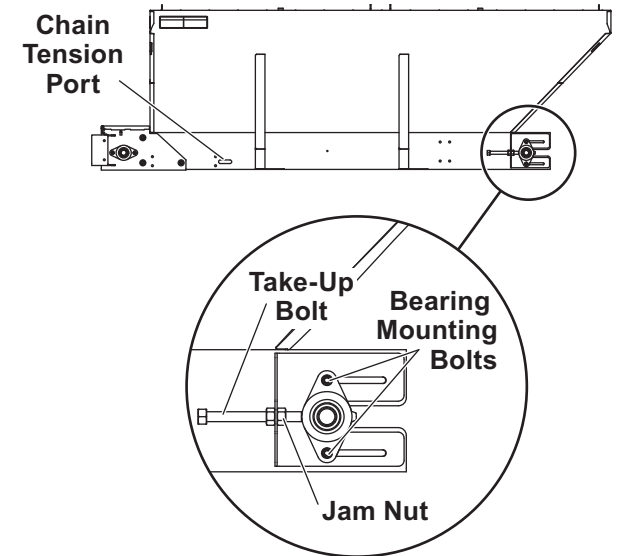

7. Run the spreader to verify that the chain tension is correct and running true. Make adjustments as needed.

**NOTE: Having the conveyor chain too tight will put additional load on the entire drive system and will increase the amperage draw on electric units.**

**NOTE: On electric units, make sure to calibrate the empty hopper function of the control.**

# STEEL HOPPER SPREADERS – GAS, ELECTRIC & HYDRAULIC MODELS

---

## CONVEYOR PINTLE CHAIN TENSION

1. Periodically check the conveyor chain tension. The spreader should be out of the vehicle. To check the tension, measure in 20"-24" from the rear edge of the sills. Push up on the chain with your hand. The conveyor chain should lift up 1"-3" off the conveyor chain guide.
2. If the slack is greater than 3", loosen the two bearing mounting bolts on each side of the conveyor idle roller on cab end of hopper.
3. Loosen the jam nut on one of the take-up bolts, then tighten (clockwise) the take-up bolt one full revolution. Repeat evenly on the other side.

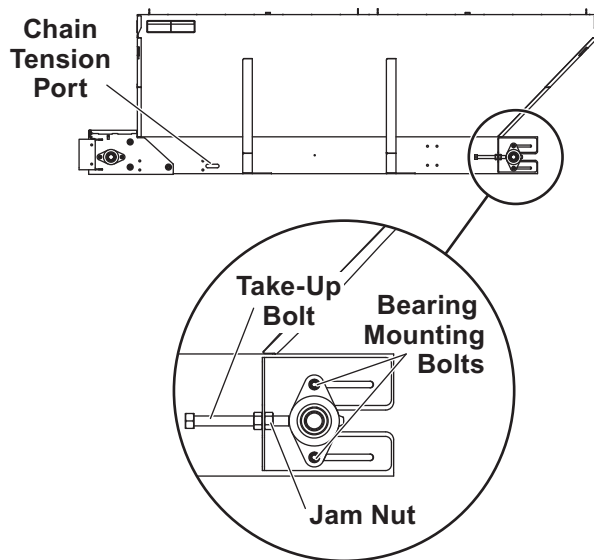

## STEEL HOPPER SPREADERS – GAS MODELS: CHUTE LENGTH ADJUSTMENT

The material chute for hopper spreaders with gasoline engines comes in two lengths.

- **8' Hoppers:** Short chute configuration is standard. The chute extends 14.75" below the truck bed and will fit most pickup trucks.
- **9' and 10' Hoppers:** Long chute configuration is standard. The chute extends 26.75" below the truck bed. The long chute configuration is required for flat bed and dump truck installations.

Long Chute

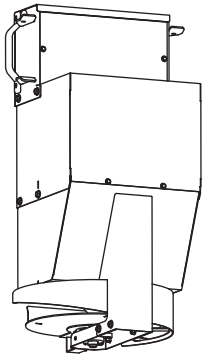

Short Chute

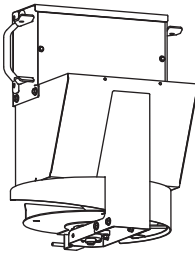

Ideal spinner height is 12"–18" above the ground. For some installations, the chute length may need to be adjusted to achieve the desired spinner height.

***If no chute length adjustment is required,*** go to "Install Chute to Spreader – Gas Models."

### Changing from Short Chute to Long Chute Configuration – Gas Models

1. Remove chute from spreader if installed.
2. Loosen the set screws on the lower bearing collar.
3. Loosen the set screws on the upper bearing collar. Remove the spinner bolt. Set the bolt and spinner aside.
4. Slide the spinner shaft out of the chute. Loosen the sprocket set screw and remove the sprocket and key and set aside. Note the position of the sprocket in relation to the end of the shaft.
5. Remove and retain the four fasteners that attach the upper and lower sections together.
6. Open the shaft extension kit and inventory the parts in the kit (middle section, long spinner shaft, bolt bag).
7. Attach the middle section to the lower section using four 3/8"-16 x 3/4" cap screws, 3/8" nuts, 3/8" lock washers, 3/8" flat washers, and two 1/4"-20 x 3/4" cap screws, four 1/4" flat washers, and two 1/4"-20 locknuts.
8. Attach the middle section to the upper section using four 3/8"-16 x 3/4" cap screws, 3/8" nuts, 3/8" lock washers, and 3/8" flat washers.
9. Install the key and sprocket onto the long spinner shaft. Locate the sprocket at the same location as it was on the short shaft. Tighten the set screw.
10. Feed the shaft down through the top bearing, through the spinner, and into the lower bearing. Tighten the set screws on the upper and lower bearings.
11. Reinstall the spinner bolt and nut.
12. Check that the spinner shaft spins freely.
13. Install the chute on the spreader.

# STEEL HOPPER SPREADERS – GAS MODELS: CHUTE ADJUSTMENT

## Changing Long Chute to Short Chute Configuration

A short spinner shaft is shipped with the 9' and 10' hoppers so that the chute can be reconfigured if necessary. The chute must be separate from the hopper for this procedure.

### 1. Remove the long spinner shaft.

- a. Loosen the set screws on the lower bearing collar.

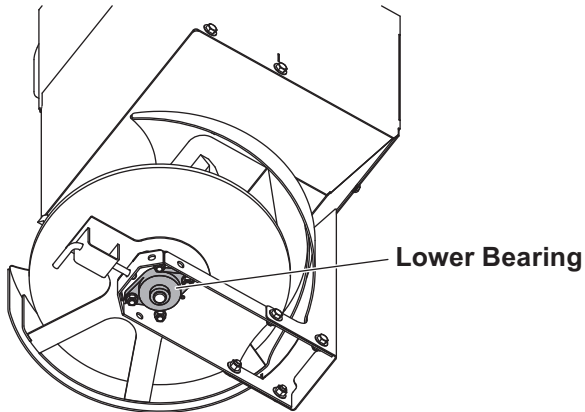

- b. Loosen the set screws on the upper bearing collar. Remove the spinner bolt. Set the bolt and spinner aside.

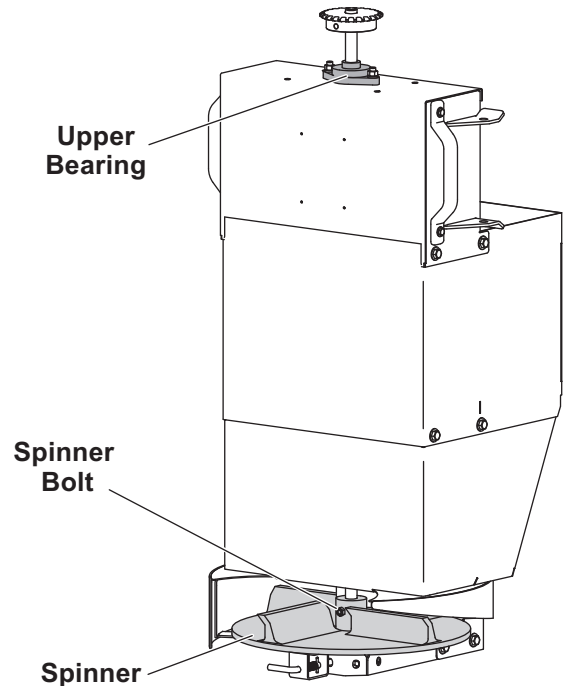

- c. Remove the sprocket and key from the top of the shaft by loosening the sprocket set screw.

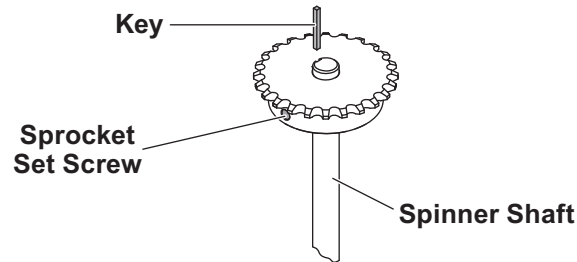

### 2. Shorten the chute.

- a. Remove the six fasteners that attach the middle and lower sections of the chute and

the four fasteners that attach the middle and upper sections. Remove the middle section.

- b. Install the lower chute section to the upper section using the four upper fasteners removed in the previous step.

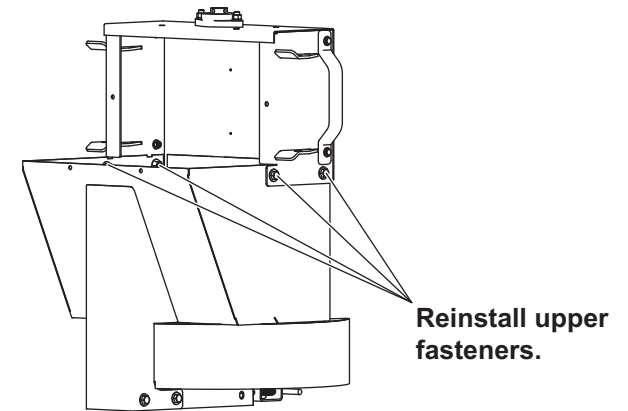

### 3. Install the short spinner shaft supplied with the hopper.

- a. Install the sprocket and key to the short shaft. The top of the spinner shaft should be flush with the top face of the sprocket.
- b. Feed the shaft through the top bearing, spinner, and lower bearing. Tighten the set screws on the upper and lower bearings.
- c. Reinstall the spinner bolt and tighten the locknut.
- d. Check that the spinner shaft spins freely.

# STEEL HOPPER SPREADERS – GAS MODELS: CHUTE INSTALLATION

## Install Chute to Spreader – Gas Models

1. Unlatch the access door on both sides. Lift the door and slide it inward to hold it open.
2. Pick up the chute from each side and slide the chute-side hinge plates over the hopper-side hinge plates. Two people are recommended for this step.

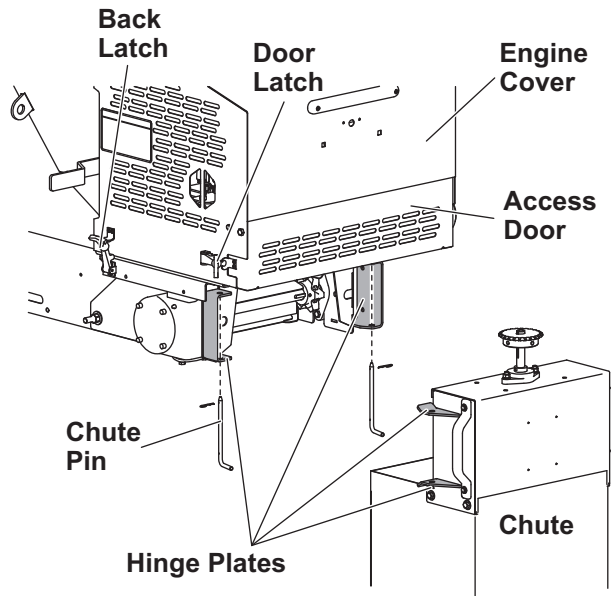

3. Line up the hinge pivot holes. Insert a 1/2" x 8-1/4" chute pin on each side, with the passenger-side pin inserted from below. Secure the chute pins with 3/32" x 2-1/4" cotter pins.
4. Release both back latches and lift the engine cover.

5. Using a straight edge, check the alignment of the spinner shaft and spinner drive sprockets.

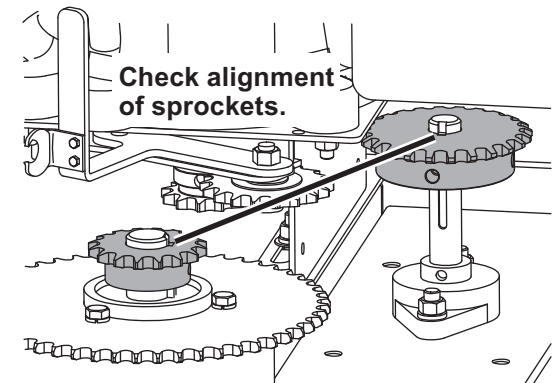

6. To adjust sprocket alignment, loosen the spinner sprocket set screw, adjust the sprocket position up or down as required, and retighten the set screw.
7. Install the drive chain over the spinner shaft and spinner drive sprockets.

65



## STEEL HOPPER SPREADERS – GAS MODELS: SPINNER DRIVE ADJUSTMENT

### Adjust Spinner Drive Chain Tension

1. Position the tensioner so it is fully extended, with the idler sprocket engaged with the chute drive chain.
2. Loosen the tensioner pivot bolt and nut.
3. Slide the tensioner toward the chain until the chain is tight.
4. Tighten the tensioner pivot bolt nut.

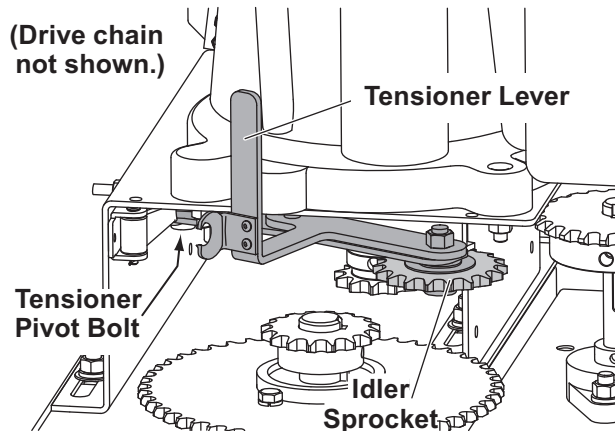

5. Loosen the tensioner adjustment bolt jam nut and advance the adjustment bolt until it contacts the tensioner pivot bolt nut. This will keep the pivot bolt from moving.

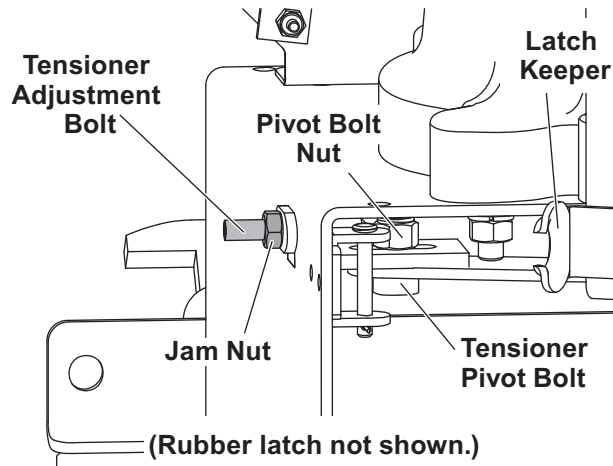

6. Tighten the tensioner adjustment bolt jam nut.
7. Check the chain tension. Correct tension allows the chain to move 1/4" when pressed midway between the sprockets. To adjust the tension, repeat Steps 2–6 as required.

8. Tighten the tensioner pivot bolt nut to 30 ft-lb. Tighten the tensioner adjustment bolt jam nut.
9. Hook the rubber latch into the latch keeper on the tensioner lever.

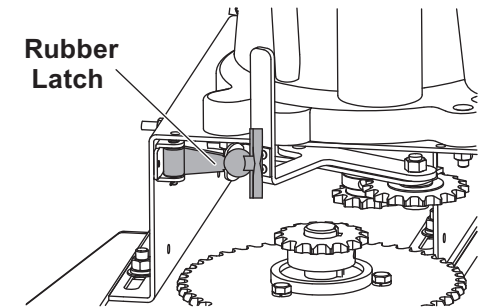

10. Close the engine cover and secure the back latches. Close and latch the access door.



## STEEL HOPPER SPREADERS – HYDRAULIC MODELS: CHUTE LENGTH ADJUSTMENT

---

### Changing from Short Chute to Long Chute Configuration – Hydraulic Models

1. Disconnect the chute hydraulic hoses.
2. Remove chute from spreader if installed.
3. Loosen the set screws on the lower bearing collar.
4. Remove and retain the coupling pin from the top of the spinner shaft.
5. Remove and retain the four fasteners that attach the upper and lower sections together.
6. Open the shaft extension kit and inventory the parts in the kit (middle section, long spinner shaft, bolt bag).
7. Attach the middle section to the lower section using four 3/8"-16 x 3/4" cap screws, 3/8" nuts, 3/8" lock washers, 3/8" flat washers, and two 1/4"-20 x 3/4" cap screws, four 1/4" flat washers, and two 1/4"-20 locknuts.
8. Attach the middle section to the upper section using four 3/8"-16 x 3/4" cap screws, 3/8" nuts, 3/8" lock washers, and 3/8" flat washers.
9. Install the long shaft up through the lower bearing and spinner, and into the hydraulic motor coupling. Pin the shaft to the coupling using the retained pin.
10. Tighten the lower bearing set screws.
11. Reinstall the spinner bolt.
12. Confirm that the spinner shaft spins freely.
13. Reinstall the chute on the spreader.

# STEEL HOPPER SPREADERS – HYDRAULIC MODELS: CHUTE LENGTH ADJUSTMENT

## Changing Long Chute to Short Chute Configuration

A short spinner shaft is shipped with the 9' and 10' hoppers so that the chute can be reconfigured if necessary. The chute must be separate from the hopper for this procedure.

1. Remove the long spinner shaft.
  - a. Loosen the set screws on the lower bearing collar.

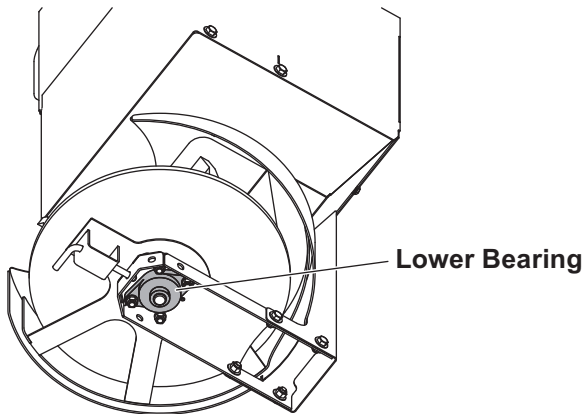

- b. Remove and retain the coupling pin from the top of the spinner shaft.

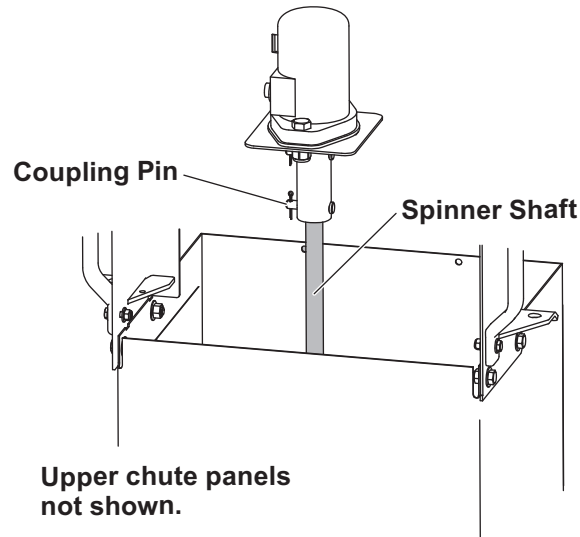

- c. Remove the spinner bolt. Set the bolt and spinner aside

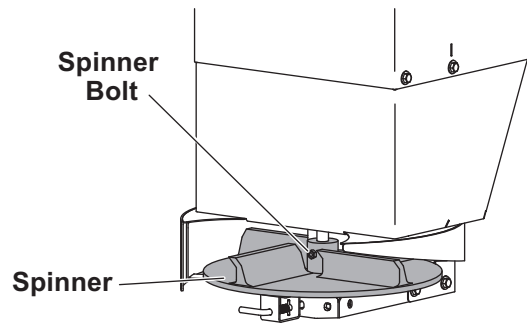

- d. Slide the shaft out of the chute. Remove the shaft from the hydraulic motor coupler.

2. Shorten the chute.
  - a. Remove the six fasteners that attach the middle and lower sections of the chute and the four fasteners that attach the middle and upper sections. Remove the middle section.
  - b. Install the lower chute section to the upper section using the four upper fasteners removed in the previous step.
3. Install the short spinner shaft.
  - a. Feed the shaft through the lower bearing and spinner, and into the hydraulic motor coupling joint. Pin the shaft to the coupling using the retained pin.
  - b. Tighten the lower bearing set screws.
  - c. Reinstall the spinner bolt.
  - d. Confirm that the spinner shaft spins freely.

## STEEL HOPPER SPREADERS – HYDRAULIC MODELS: CHUTE INSTALLATION

---

### Install Chute to Spreader – Hydraulic Models

1. Pick up the chute from each side and slide the chute-side hinges over the hopper-side hinges. Two people are recommended for this step.
2. Line up the hinge pivot holes. Insert a 1/2" x 8-1/4" chute pin from below on each side and secure with a 3/32" x 2-1/4" cotter pin.

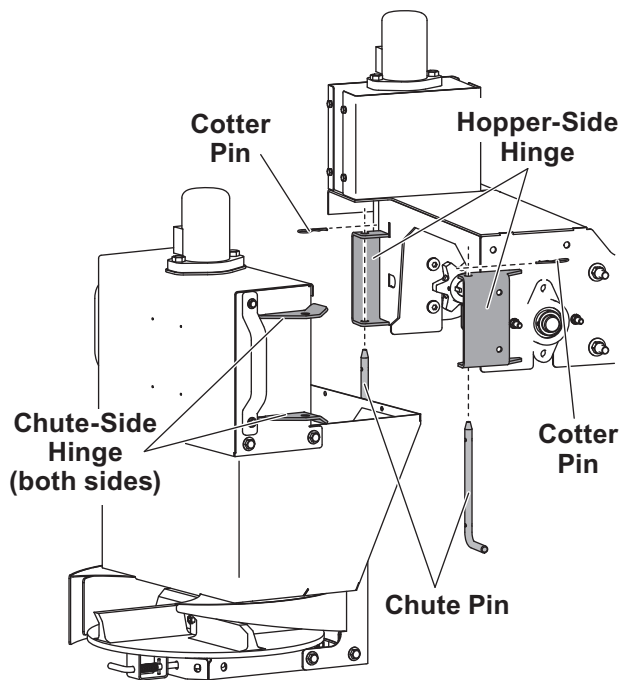

3. Once the chute is in place, install the hydraulic hoses.

# STEEL HOPPER SPREADERS – ELECTRIC MODELS: CHUTE LENGTH ADJUSTMENT

## Changing from Short Chute to Long Chute Configuration – Electric Models

1. Remove chute from spreader if installed.
2. Remove the two 1/4"-20 bolts that attach the motor cover plate to the upper section of the chute. Cut the wire ties holding the extra harness length and extend. Disconnect the motor leads from the harness.
3. Remove and retain the four fasteners that attach the upper and lower sections together. Separate the two sections, being careful not to damage the electrical harness.
4. Open the shaft extension kit and inventory the parts in the kit (middle section and bolt bag).
5. Attach the middle section to the lower section using four 3/8"-16 x 3/4" cap screws, 3/8" nuts, 3/8" lock washers, 3/8" flat washers, and two 1/4"-20 x 3/4" cap screws, 1/4" four flat washers, and two 1/4"-20 locknuts.

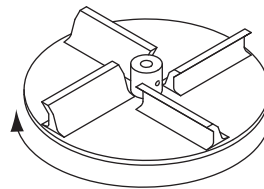

6. Install the rubber bushing into the 1" diameter hole in the back corner of the midsection. Route the electrical harness from the upper section down through the bushing. Reconnect the harness to the motor leads and verify that the harness will not contact any moving parts. Reinstall the motor cover plate that was originally attached to the upper section.
7. Attach the middle section to the upper section using four 3/8"-16 x 3/4" cap screws, 3/8" nuts, 3/8" lock washers, and 3/8" flat washers.
8. Verify that the spinner moves freely.
9. Reinstall the chute on the spreader.
10. Run the spreader to verify correct operation. Pay attention to the spinner. It should turn in a clockwise rotation. If not, swap the spade connections at the motor leads.

## Changing Long Chute to Short Chute Configuration

The chute must be separate from the hopper for this procedure.

1. Remove the six fasteners that attach the lower and middle chute sections and the four fasteners that attach the middle and upper sections. Remove the middle section.
2. Install the lower chute section to the upper section using the four upper fasteners removed in Step 1.

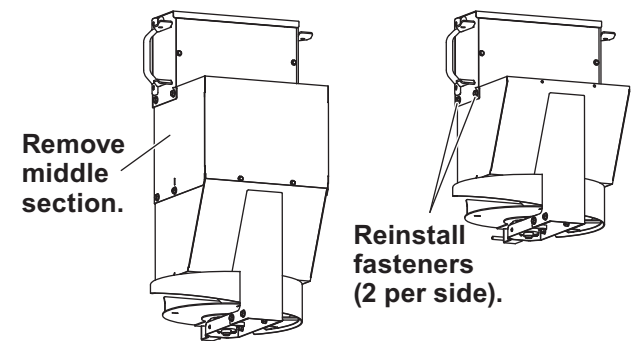

3. Loop up the excess length of the cable and secure it to the corner bracket using cable ties. Remove the cover from the middle section and reinstall on upper section.

70

---

# SPREADER ACCESSORIES

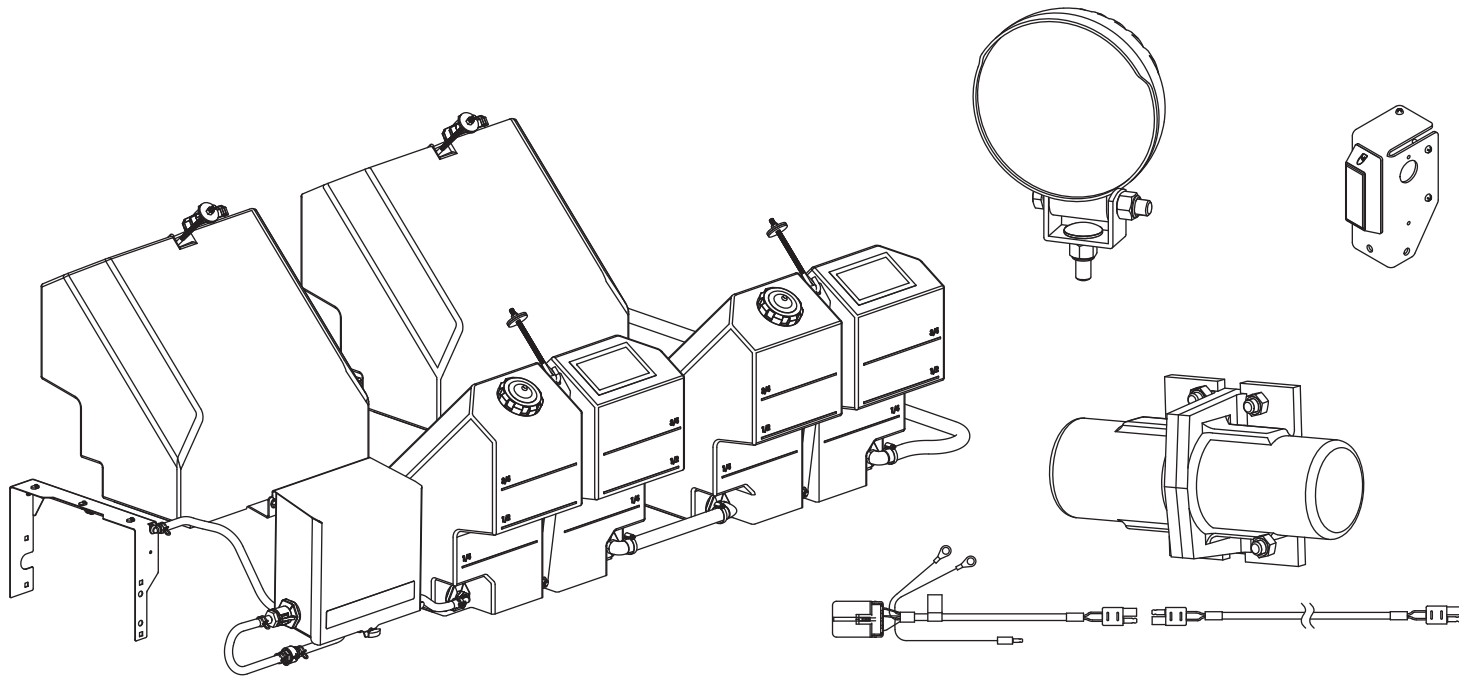

# ACCESSORIES – STROBE LIGHT

---

## STROBE LIGHT OPERATION

The strobe light comes with a pre-set flash pattern. In some instances, it is possible for this default pattern to change to a "Steady On" mode. Should this occur, the flash pattern can be changed to any of 11 flash patterns.

1. Cut the wire seal off the yellow wire and strip 1/4" of insulation.
2. With the strobe ON, intermittently apply 12V from the vehicle power supply to the yellow wire until the strobe achieves the desired flash pattern:

MODE	PATTERN
0	Random
1	Steady
2	Single
3	Mega
4	Double
5	Triple
6	Quad
7	Quint
8	8 Flash
9	Single-Quad
10	Single H/L
11	Single-Triple-Quint

3. Reseal the yellow wire.

---

**NOTE: The white wire is not used.**

---

Excerpts taken from Strobe Light Kit Steel Hopper Spreader Installation Instructions (Lit. No. 92945, Rev. 04).

# ACCESSORIES – PRE-WET KIT: FULL-FEATURE CONTROL

## HARNESS WIRING DIAGRAM

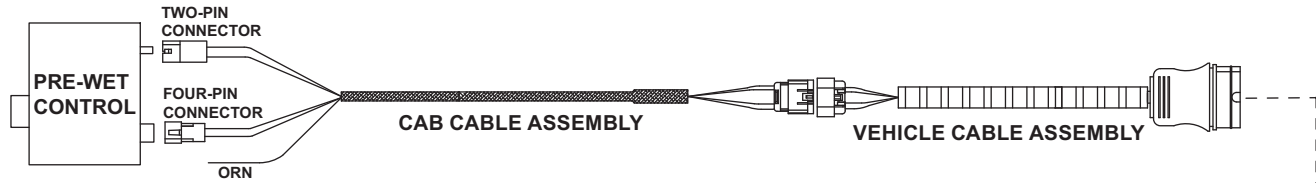

**NOTE:** Installation Instructions and Owner's Manual for the Pre-Wet Kits (Lit. No. 70427 and 70429) can be found on the website: [www.fisherplows.com](http://www.fisherplows.com).

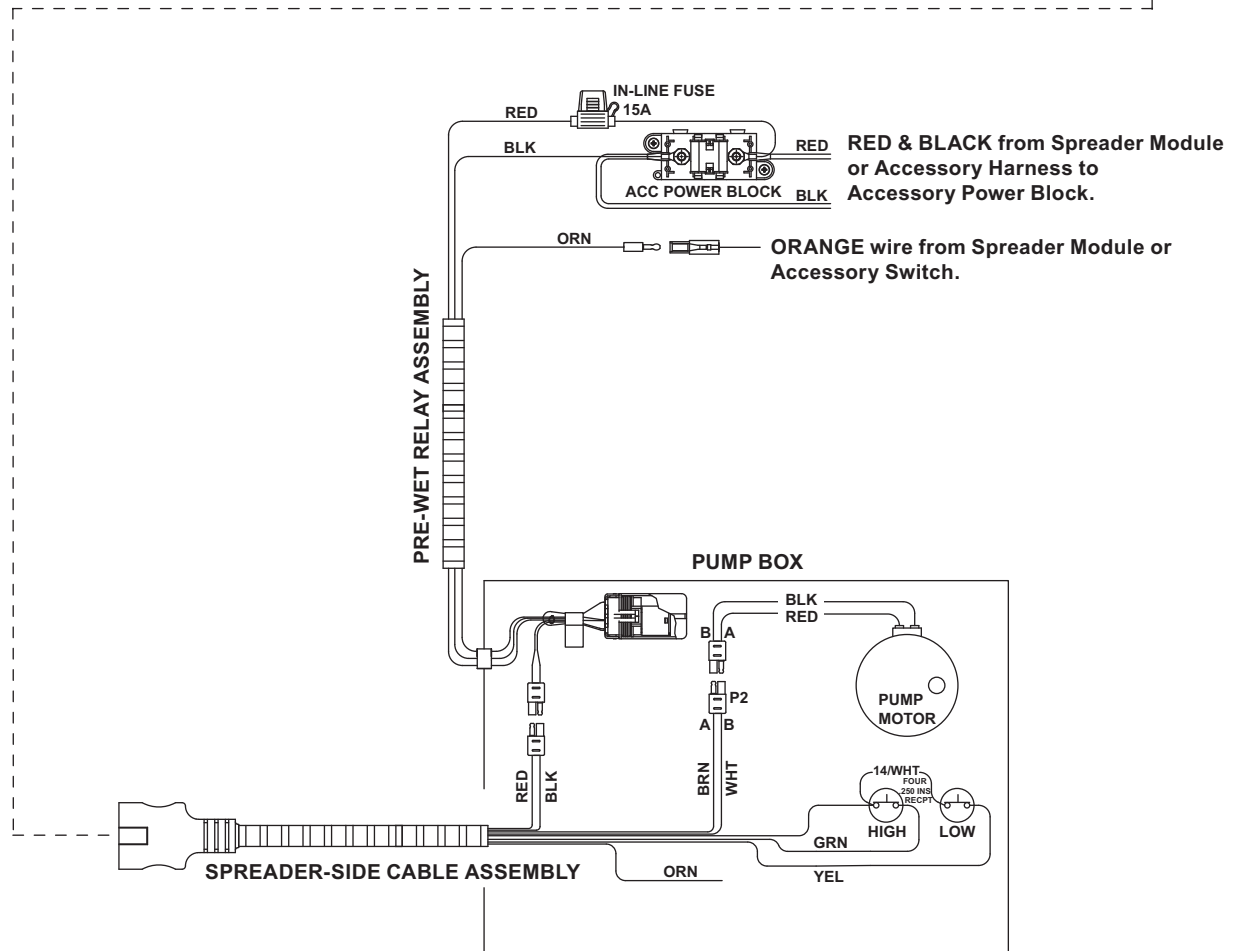

# ACCESSORIES – PRE-WET KIT: FULL-FEATURE SYSTEM (STEEL & POLY HOPPER SPREADERS)

## HARNESS WIRING DIAGRAM – FULL-FEATURE SYSTEM

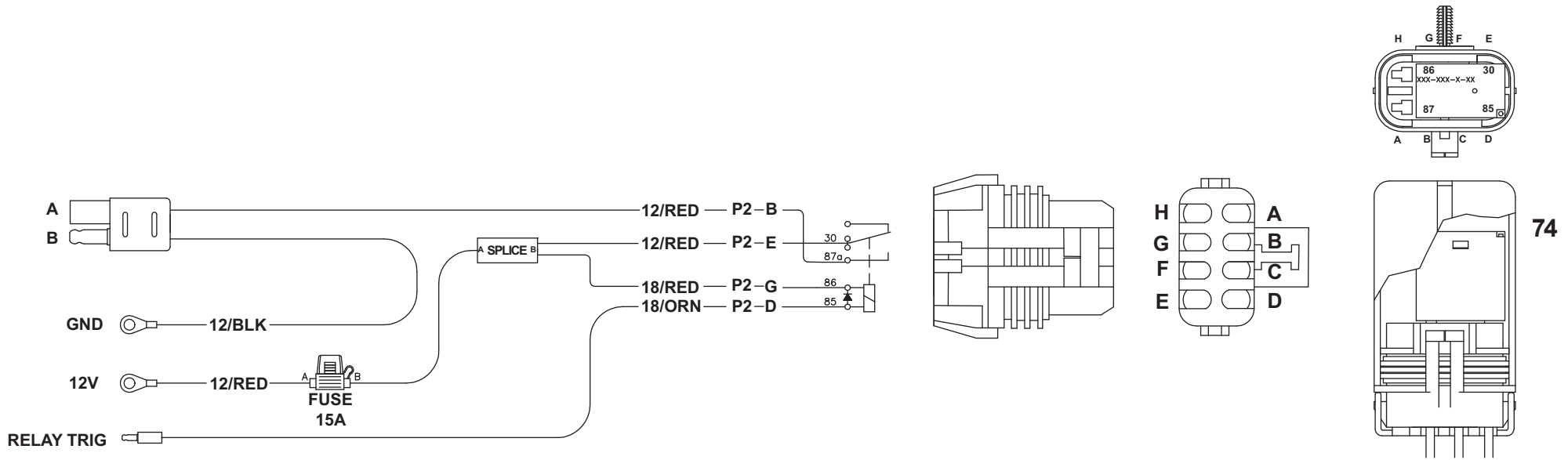



## ACCESSORIES – PRE-WET KIT: FULL-FEATURE SYSTEM (STEEL & POLY HOPPER SPREADERS)

### TROUBLESHOOTING GUIDE

Problem	Possible Cause	Suggested Solution
<b>Tank Empty light is on but tank is not empty.</b>	1. Strainer is clogged.	1. Clean the strainer.
	2. Feed line is clogged.	2. Remove the feed line and clear out the clog.
	3. Pump seized.	3. Replace the pump.
	4. Tank valve is closed.	4. Open the tank valve.
	5. Bad pressure switch, 3 psi (Normally Closed NC).	5. Test; replace as needed.
<b>High psi light is on.</b>	1. Spray hose is clogged.	1. Clean spray hose with fresh water.
	2. Spray line is clogged.	2. Remove the spray line and clear out the clog.
	3. Check valve is on backwards.	3. Reverse the check valve.
	4. Bad pressure switch, 40 psi (Normally Open NO).	4. Test; replace as needed.
<b>Pump is not operating.</b>	1. Loose electrical connection.	1. Check all electrical connections for corrosion.
	2. Blown fuse.	2. Replace the fuse.
	3. Pump seized.	3. Replace the pump.
<b>Control shut down.</b>	1. Loose electrical connection.	1. Check all electrical connections for corrosion.
	2. Electrical short.	2. Check for bare or burned wires.
	3. Control failure.	3. Replace the control.
	4. Blown fuse.	4. Replace the fuse.
<b>Material being spread is not wet.</b>	1. Pre-wet system is not running.	1. See "Pump is not working" in the Troubleshooting section of Owner's Manual/Installation Instructions.
	2. Spray hose is misaligned.	2. See "Aligning the Spray Hose" in the Owner's Manual/Installation Instructions.
	3. Flow rate is set too low.	3. See "Adjusting the Flow" in the Owner's Manual/Installation Instructions.
<b>Spray is uneven.</b>	1. Spray hose is clogged.	1. Clean spray hose with fresh water.
	2. Spray hose is damaged.	2. Replace the spray hose.
<b>Pump is leaking.</b>	1. O-ring fittings are loose.	1. Verify that O-ring fittings are fully installed.
	2. O-rings are damaged or worn.	2. Replace the O-rings.
	3. Pump housing is damaged.	3. Replace the pump.

# ACCESSORIES – PRE-WET KIT: ON/OFF CONTROL (STEEL & POLY HOPPER SPREADERS)

## HARNESS WIRING DIAGRAM – ON/OFF

### ON/OFF SYSTEM STAINLESS STEEL/POLY (GEN 2.5) HOPPERS

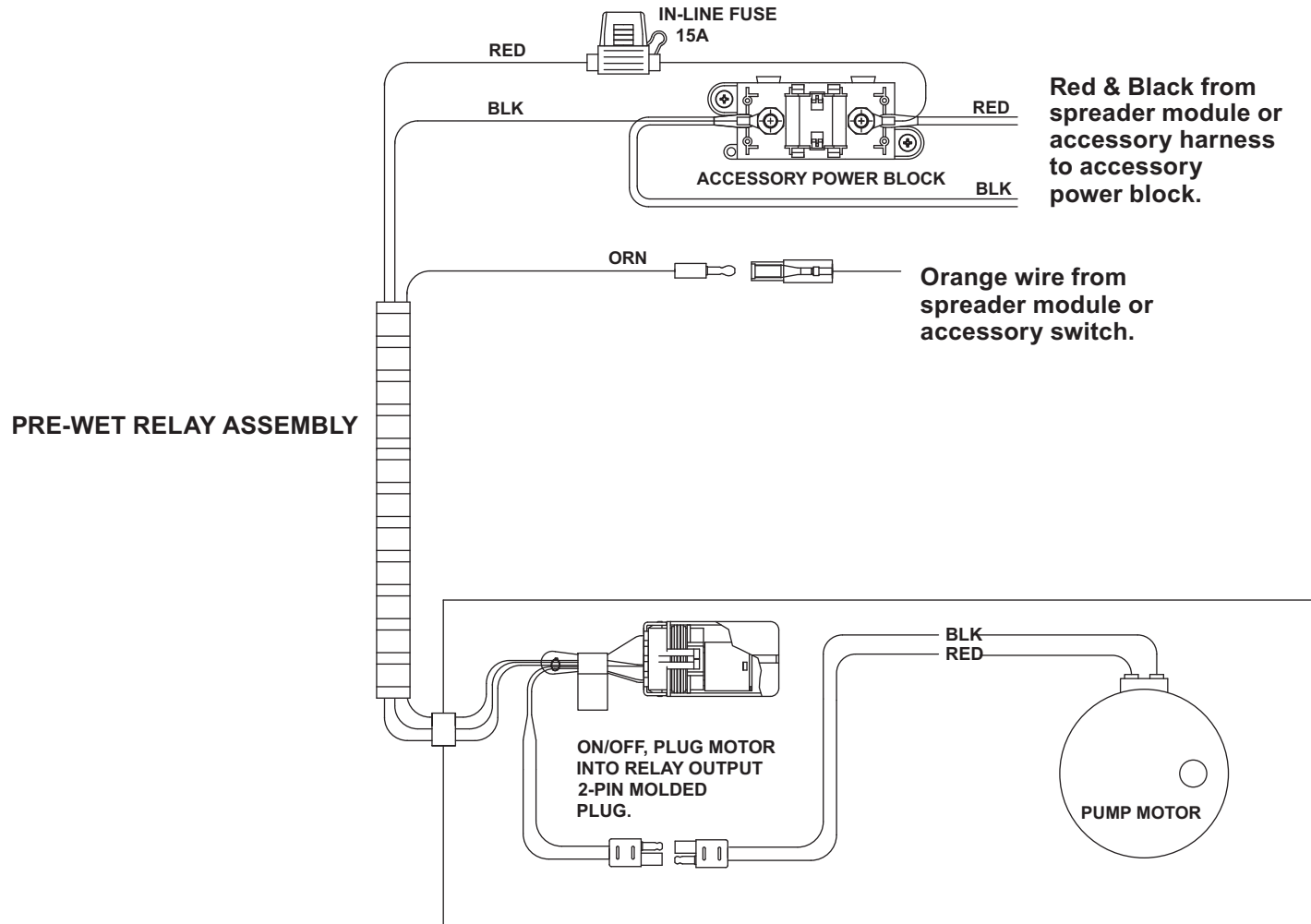

## ACCESSORIES – PRE-WET KIT: ON/OFF CONTROL (STEEL & POLY HOPPER SPREADERS)

### TROUBLESHOOTING GUIDE

Problem	Possible Cause	Suggested Solution
<b>Pump is not operating.</b>	1. Loose electrical connection.	1. Check all electrical connections for corrosion.
	2. Blown fuse.	2. Replace the fuse.
	3. Pump seized.	3. Replace the pump.
<b>Control shut down.</b>	1. Loose electrical connection.	1. Check all electrical connections for corrosion.
	2. Electrical short.	2. Check for bare or burned wires.
	3. Control failure.	3. Replace the control.
	4. Blown fuse.	4. Replace the fuse.
<b>Material being spread is not wet.</b>	1. Pre-wet system is not running.	1. See "Pump is not working" in the Troubleshooting section of Owner's Manual/Installation Instructions/Parts List.
	2. Spray hose is misaligned.	2. See "Aligning the Spray Hose" in the Owner's Manual/Installation Instructions/Parts List.
	3. Flow rate is set too low.	3. See "Adjusting the Flow" in the Owner's Manual/Installation Instructions/Parts List.
<b>Spray is uneven.</b>	1. Spray hose is clogged.	1. Clean spray hose with fresh water.
	2. Spray hose is damaged.	2. Replace the spray hose.
<b>Pump is leaking.</b>	1. O-ring fittings are loose.	1. Verify that O-ring fittings are fully installed.
	2. O-rings are damaged or worn.	2. Replace the O-rings.
	3. Pump housing is damaged.	3. Replace the pump.

# ACCESSORIES – PRE-WET KIT: ON/OFF LEGACY SYSTEM (POLY II HOPPER SPREADERS)

## HARNESS WIRING DIAGRAM – ON/OFF, LEGACY POLY II HOPPER SPREADERS

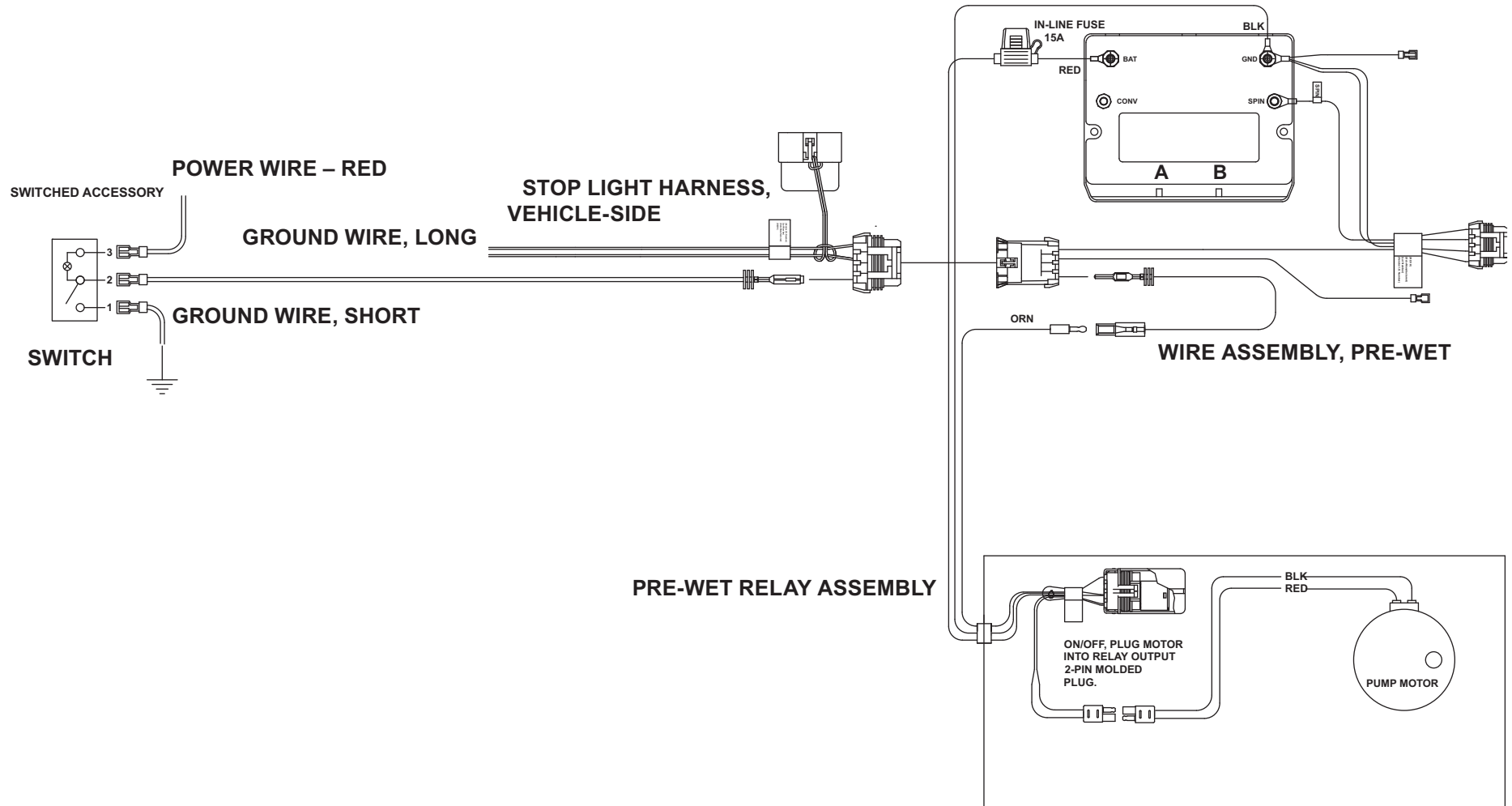

# ACCESSORIES – PRE-WET KIT: ON/OFF LEGACY POLY II HOPPER SPREADER SYSTEM

## HARNESS WIRING DIAGRAM – PRE-WET RELAY HARNESS

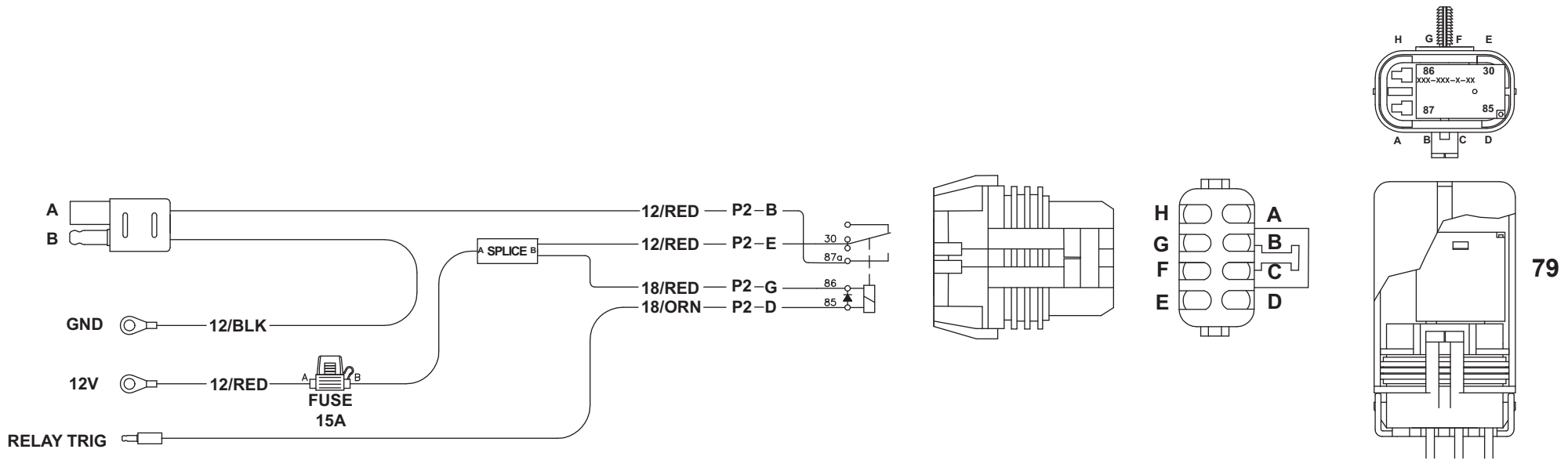

## ACCESSORIES – PRE-WET KIT: MAINTENANCE

---

### PERIODIC MAINTENANCE

- Wash unit after each use to prevent material build-up and corrosion.
- Use dielectric grease on all electrical connections to prevent corrosion each time power or signal plugs are disconnected.
- Inspect unit for defects: broken, worn, or bent parts and similar.
- Inspect all tubing, hoses, and harnesses for cracks and leaks.
- Clean the brine filter as needed. Close the shut-off valve and access the filter by unscrewing the top cap, then unscrewing the filter cover.
- Retighten bolts, screws, and other connections after first use and as needed.

### CLEANING

- Clean the unit as desired. When power washing, keep away from electronics.
- Use caution if you are flushing the pumping system with water as it will accumulate in the valves and can cause damage if the water inside freezes. Use non-toxic antifreeze if unit is to be stored in freezing temperatures.

### END OF SEASON AND STORAGE

- Before long periods of storage, flush out the tanks and pumping system to remove salt build-up and prevent corrosion.
- Do not leave unused material in the unit for a prolonged period of time.

# ACCESSORIES – PRE-WET KIT

## ELECTRICAL SCHEMATICS

### ON/OFF SYSTEM, STAINLESS STEEL/POLY (GEN 2.5) HOPPERS

PRE-WET RELAY ASSEMBLY

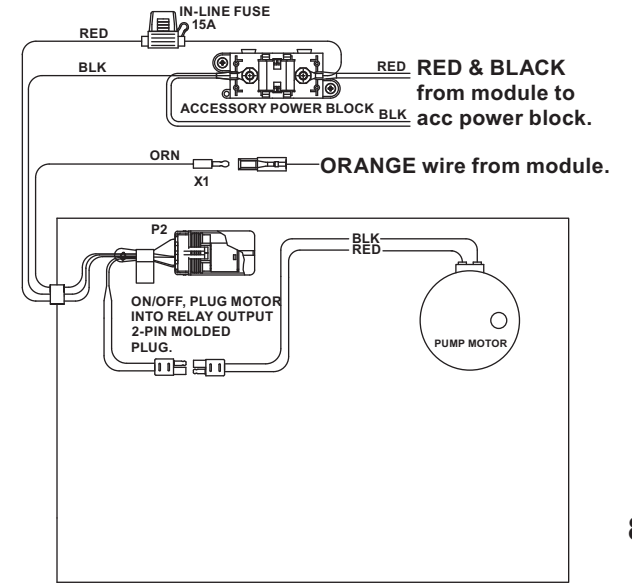

81

### DELUXE SYSTEM, STAINLESS STEEL/POLY (GEN 2.5) HOPPERS

PRE-WET RELAY ASSEMBLY

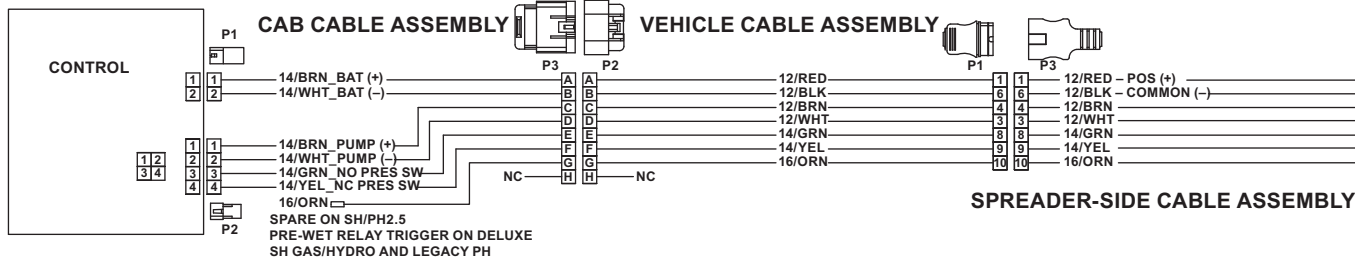
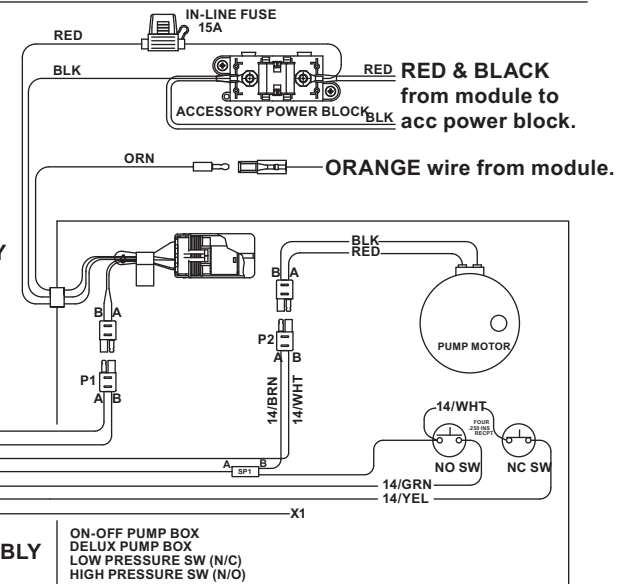

---

# **SPEED-CASTER™ & LOW-PROFILE Tailgate Spreaders**

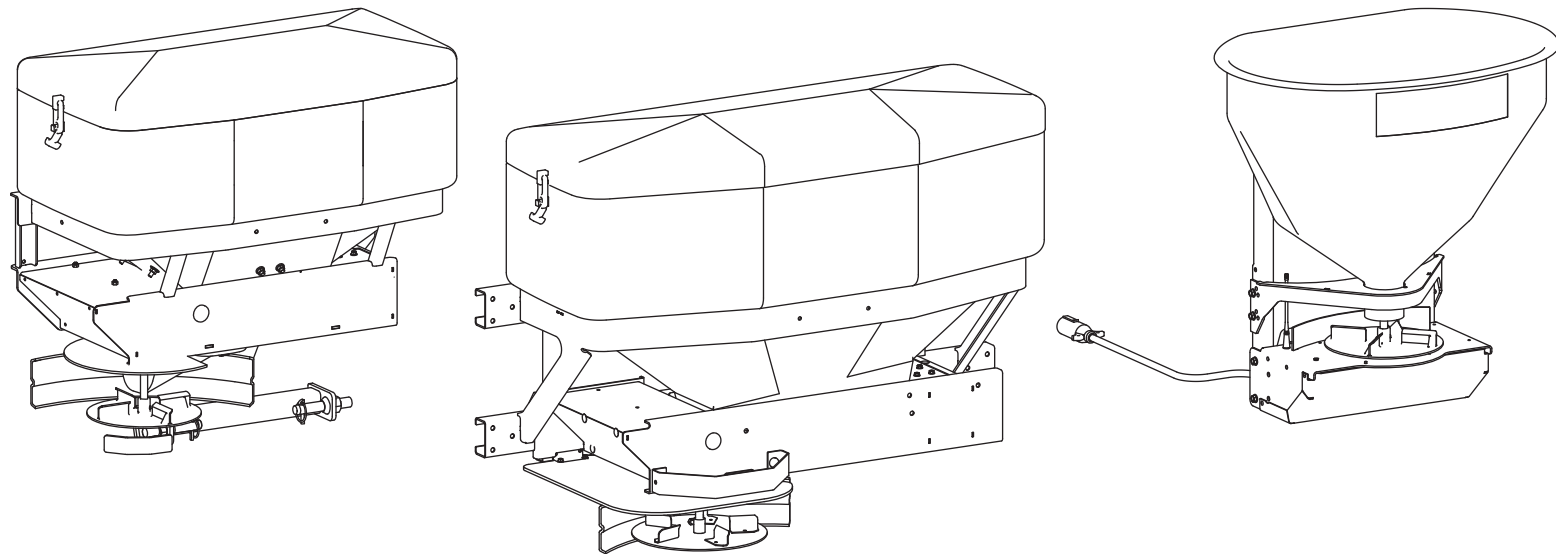



## TAILGATE SPREADERS

---

### ELECTRICAL SYSTEM (APPROXIMATE)

Amperage Draw		
Model/Components	Hopper Empty	Hopper Full of Sand
SPEED-CASTER™ Tailgate Spreader		
Spinner	3–5A	8–10A
Auger Motor	7–9A	–
Vibrator	–	14–18A
Module Current* (Vibrator ON)	4–14A	10–33A
Spinner, Auger, Vibrator	13–17A	30–35A
LOW-PROFILE Wireless Tailgate Spreader	3.5A	10A

\* Reading at the BAT/GND of the module.

# TAILGATE SPREADERS: OPERATING THE SPREADER – CAB CONTROL

---

## CONTROLLING MATERIAL APPLICATION

The material application settings can be adjusted while spreader is ON or OFF. Settings are shown by the indicator lights around the control knobs. When the spreader is OFF, a single LED will light to show the current setting. When the spreader is ON, the number of blue LEDs illuminated will increase/decrease as the knobs are turned clockwise/counterclockwise.

The auger drive will not deliver material until the ON button is pressed.

The Material Width (left) knob controls spinner speed. Turning the knob clockwise will increase the width of the application area.

The Material Flow (right) knob controls the auger drive. Turning the knob clockwise will increase the feed rate of material to the spinner.

Turning the control knobs counterclockwise will decrease the width of the application area and the feed rate of material.

## BLAST/Maximum Application

1. Press and hold the BLAST button when maximum flow rate and application area are needed temporarily. The BLAST button will illuminate while depressed.
2. Release the button when maximum application settings are no longer needed.

---

**NOTE: Spinner speed and material feed rate revert to the previous settings once the BLAST button is released.**

---

## CAB CONTROL MODES

### Standby Mode

Vehicle ignition is set to ACC or ON; cab control is OFF. Control has power. No spreader was detected. No lights are illuminated on the control. Press any button to wake.

### Ready Mode

Vehicle ignition is set to ACC or ON; cab control is OFF. Control has power. Spreader is detected.

The Material Width and Material Flow control knobs can be set to start-up conditions, but the spinner and drives will not operate until the cab control is turned ON.

Accessory lights and vibrator are operational. The BLAST function is not operational.

### ON Mode

Vehicle ignition is set to ACC or ON; cab control is ON.

Spinner and hopper motors will start. All cab control functions are operational. Accessory lights and vibrator are operational.

During normal spreader operation, no control codes are displayed. Information or setup codes will appear when relevant. These codes will not stop spreader operation.

### Error Mode

When an error condition occurs, spreader operation will shut down. A two-digit error code will flash on the display and a beep will sound. If there are multiple error codes, the codes will flash in a repeating sequence.

Refer to the Error Codes portion of the following Cab Control Codes table. Also see the Tailgate Spreaders: Troubleshooting Guide section of this manual.

Once the error condition has been resolved, press the ON/OFF button to clear the error code(s). Press the ON/OFF button again to resume spreader operation.

The error code will reappear if the error condition has not been rectified. If the error condition persists, contact your authorized dealer.

Multiple resets within a short time frame will cause the hopper module to time out if components are overheating. The control will display an **EF** error code.

Accessory work lights and strobe lights can be used when an error code is in effect, and will remain in their current state. The vibrator and accessory lights will not function.

## TAILGATE SPREADERS: OPERATING THE SPREADER – CAB CONTROL

### CAB CONTROL CODES

Setup Codes		
Code	Definition	Procedure
<b>Cb</b>	Calibrate the Empty Hopper setting.	With control in ON mode, press and hold the left control knob until the <b>Cb</b> code displays. Calibration cycle is automatic.*
<b>Cc</b>	Clear calibration data for Empty Hopper setting; clear <b>EH</b> code.	Press the right control knob to clear all calibration data during the calibration cycle.
<b>LS</b>	Set LED brightness level.	With control in Ready mode, press and hold left control knob to get <b>LS</b> code. Release pressure and turn left control knob to desired brightness setting. Wait for confirming <b>SL</b> code to display.*
<b>SL</b>	Confirms that LED brightness level has been reset.	

\* For full instructions, see the Tailgate Spreaders: Setup Procedures section of this manual.

Information Codes		
Code	Definition	Response
<b>Ar</b>	Auto-reverse sequence is active.	The spreader will automatically detect and attempt to clear a jam. See the Tailgate Spreaders: Operating the Spreader section of this manual.
<b>dU</b>	Not applicable to tailgate spreaders. Possibly indicates a harness or module issue.	Contact authorized dealer.
<b>EH</b>	Empty hopper (beep will sound).	Check hopper for material. Recalibrate Empty Hopper setting as described above for <b>Cb</b> code.
<b>Lb</b>	Low battery. Hopper module is sensing <10V. ( <b>Lb</b> becomes an error code when module senses $\leq 6V$ .)	Refer to the <b>Lb</b> row under "Error Codes" (see table below).

85

Error Codes – Spreader Operation Stopped			
Code	Definition	Possible Cause	Suggested Solution
<b>bb</b>	Bad button.	Button is stuck. Button was pressed while vehicle ignition was entering ACC or START mode. Possible harness issue.	Inspect control. Free up button. Do not press any spreader cab control buttons while the vehicle ignition is being engaged. Check connections and integrity of vehicle harness.
<b>bH</b>	Bad hopper.	Possible module or control mismatch.	Replace control or module. Use only genuine service parts. Contact authorized dealer.
<b>CE</b>	No communication with spreader module.	Loose connection. Module lost power.	Confirm that spreader and control harnesses are connected to the vehicle harness. Check fuses, power to spreader module, all connections, and power studs. Check that port B is plugged into the module.
<b>CF</b>	Control malfunction.	Control is overheating. May be a combination of faults.	Inspect connections at spreader module, hopper drive motor, and spinner drive motor.

Table continues on next page.

## TAILGATE SPREADERS: OPERATING THE SPREADER – CAB CONTROL

### Cab Control Troubleshooting (continued)

Error Codes – Spreader Operation Stopped – <i>continued</i>			
Code	Definition	Possible Cause	Suggested Solution
<b>CP</b>	Not applicable to tailgate spreaders. See suggested solution.	Not applicable to tailgate spreaders.	Reset the control by pressing the ON/OFF button. If <b>CP</b> code continues to display, contact authorized dealer.
<b>Ct</b>	Control is hot.	Cab temperature is too high. Control overheated.	Turn spreader OFF and allow control to cool off.
<b>EF</b>	Excessive drive faults.	Too many <b>HO</b> and/or <b>SO</b> error codes; hopper module overheating.	Control times out for 60 seconds. Ensure that auger and/or spinner are not jammed.
<b>HO</b>	Hopper overload – software trip.	Drive system has high current. Material is jammed.	Inspect auger; clear material jam.
<b>HO.</b>	Hopper overload – hardware trip.	Auger is damaged.	
<b>HP</b>	Hopper power issue. No motor present.	Hopper drive motor is not connected. Possible motor defect.	Check connections to the auger drive motor (P—FEED and FEED—N posts on the module and studs on the motor). Replace the motor.
<b>Lb</b>	Low battery. Hopper module is sensing $\leq 6V$ .	Bad connection or low battery. Snowplow or other vehicle power use may be driving down voltage.	Voltage is measured at the hopper module, so <b>Lb</b> code may indicate cable voltage loss. Check battery, alternator, and connections.
<b>nC</b>	No connection.	Spreader not connected to vehicle harness.	Connect vehicle and spreader harness. Check vehicle harness fuse. Inspect spreader and vehicle harnesses. Check module.
<b>OH</b>	Overheating.	Spreader module is too hot.	Allow a cool-off period – 60 seconds or longer. Check for loose harness connections. Check accessory connections. Check integrity of accessory wiring and harness. Clear jammed material. Contact authorized dealer.
<b>OH.</b>	Overheating module – microprocessor.	Spreader module malfunction. Accessories wiring/function problem. Drive motor overload.	
<b>rS</b>	Reset of spreader module.	Power loss to module detected on startup.	Reset the control by pressing the ON/OFF button. Check vehicle harness and battery connection.
<b>SO</b>	Spinner drive overload – software trip.	Material jammed in chute/spinner area.	Inspect spinner and spinner drive components for alignment and condition. Check for damage to bearings, shafts, and sprockets. Adjust and replace parts as required.
<b>SO.</b>	Spinner drive overload – hardware trip.	Spinner shaft is damaged.	
<b>SP</b>	Spinner power issue. No motor present.	Spinner drive motor is not connected. Possible motor defect.	Check connections to the motor (SPIN and GND posts on the module). Replace the motor.

# TAILGATE SPREADERS: OPERATING THE SPREADER – CAB CONTROL

---

## SETUP PROCEDURES

### Calibrate the Empty Hopper Setting (Cb and EH Codes)

Calibrating the empty hopper setting enables the cab control to alert the operator when the hopper is empty.

Recalibrate the empty hopper setting at the start of each ice-control season.

1. Ensure that the hopper is empty before beginning the calibration.
2. Turn the vehicle ignition to ACC or ON. Press the ON/OFF button on the cab control to turn the control ON.
3. Press and hold the Material Width (left) knob for approximately 10 seconds until the **Cb** code displays.
4. The calibration cycle will begin. The blue LEDs around the Material Flow (right) knob will illuminate in succession until all 8 are lit.
5. When the automatic calibration cycle is complete, the control will automatically revert to the previous material application settings.

If the control is turned OFF or loses power during the calibration cycle, the calibration data will be lost. Make sure the control is ON and restart the calibration process at Step 3.

Once the empty hopper setting has been calibrated, the **EH** code will flash on the display and a beep will sound whenever the hopper is empty. The **EH** code is informational only and will not stop spreader operation.

### Clearing Empty Hopper Calibration Data (Cc Code)

The empty hopper calibration may be cleared, if desired. The control will no longer display the **EH** status code when the hopper is empty.

Start the calibration cycle as described above. At Step 4, press the Material Flow (right) knob during the calibration cycle to clear *all* calibration data. The **Cc** (Clear Calibration) code will display and the control will exit **Cc** mode automatically.

### Adjust LED Brightness Level (LS and SL Codes)

The brightness setting of the cab control lights can be adjusted from 1 to 16. The factory default setting is 8.

1. Turn the vehicle ignition to ACC or ON. If necessary, press the cab control ON/OFF button to turn the control OFF.
2. Press and hold the Material Width (left) knob for approximately 3 seconds until the **LS** code is displayed.
3. Release the knob and turn it clockwise or counterclockwise to increase/decrease the brightness level. The light level number will show in the status display.
4. After selecting the desired brightness level, wait a few seconds for the **SL** confirmation code to display.

---

**NOTE: A brightness level setting of 12 or higher is recommended for daylight conditions.**

---

# TAILGATE SPREADERS: OPERATING THE SPREADER

## AUTO-REVERSE (Ar) FEATURE

The spreader is automatically able to sense and clear material jams. The sensitivity level of the auto-reverse feature is adjustable. The default value is 7 and may be adjusted if necessary.

### Changing the Default Value

1. With the spreader connected and the control powered up in the READY mode, press and hold the BLAST button. After 5 seconds, a number will appear on the status display (factory default is 7).
2. Continue to hold the BLAST button and turn the right-hand knob (material flow control knob) to change the setting (range is 2–8). Turn the knob clockwise to increase the setting. Turn the knob counterclockwise to decrease the setting.
3. Release the BLAST button.
4. Press the ON/OFF button twice (turning the spreader ON, then OFF) to save the setting.

**NOTE: Never set the auto-reverse feature to a value greater than 8 to avoid damaging the tailgate spreader.**

### Auto-Reverse (Ar) Sequence

The Ar sequence will begin automatically and consist of a series of reverse-then-forward movements of the auger.

The Ar sequence will make up to five attempts to clear the jam. The status display will flash Ar then a number, and repeat as it counts down from 5 to 1. If the jam is cleared, the auger will automatically return to normal operation at the previous control settings.

The Ar sequence may be interrupted by pressing the ON/OFF buttons, which turns OFF the spreader.

### ⚠ CAUTION

**Disconnect electric power and tag out, if required, before servicing or performing maintenance.**

If auto-reverse is unsuccessful, then the operator must extract the material that is causing the problem. Follow all warning directions when clearing jams.

### VIBRATOR FUNCTION

A heavy-duty vibrator is standard equipment on the model 525 and 900 spreaders. Turn the vibrator ON as needed to keep dense material flowing and prevent bridging of material in the hopper.

**NOTE: The vibrator is not designed for continuous duty. Allow the vibrator to cool between long cycle times.**

### CONTROLLING FLOW OF MATERIAL

The factory installed baffle plate in the spreader stops fine materials from free flowing. When dense or damp material is being spread or when more or less flow is desired, adjust the baffle extension or remove the baffle plate and baffle extension.

To adjust the baffle extension, the material baffle and extension must be removed, adjusted, and then reinstalled.

5.25 ft<sup>3</sup> Spreader

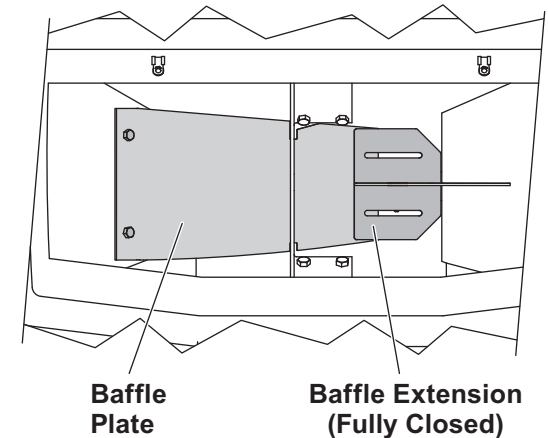

9.0 ft<sup>3</sup> Spreader

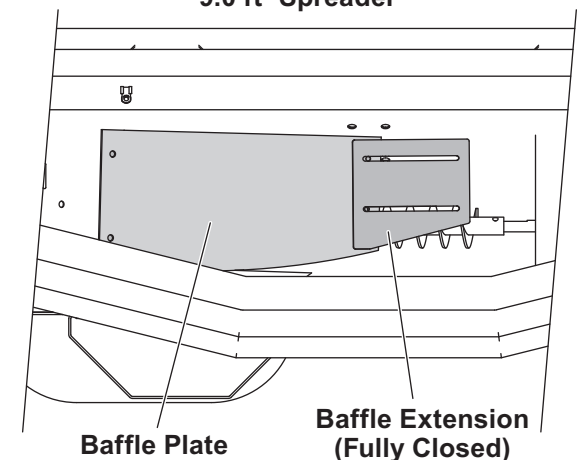

## TAILGATE SPREADERS: TROUBLESHOOTING GUIDE

Please see your distributor for service. The troubleshooting reference table below may guide you in diagnosing the issue.

For a reference table of the cab control error codes, see the Tailgate Spreaders: Operating the Spreader – Cab Control section of this manual.

Before servicing the spreader:

- Review all safety information.
- Confirm that all electrical connections are tight and clean.
- Confirm that nothing is jammed in the hopper.

Problem	Possible Cause	Suggested Solution
<b>No power to cab control.</b> Ignition and control switches ON; control knob indicator lights not illuminated.	1. Control is in standby mode. Spreader is not connected.	1. Press any button on control to wake.
	2. Control connector plug is loose.	2. Check plug connection at cab control.
	3. Switched accessory connection is poor, or faulty battery.	3a. Check for low battery. 3b. Check switched accessory connection.
	4. Blown fuse.	4. Replace spreader vehicle battery cable fuse.
	5. Vehicle control harness is damaged.	5. Repair or replace damaged wires or harness as required.
<b>Cab control shuts down.</b>	<b>Unplug the spreader harness and tag out, if required, before performing any of the following repairs.</b>	
	1. Cross-reference displayed error code with list on pages 85–86.	1a. See suggested solution on pages 85–86. 1b. Reset the control by pressing the ON/OFF button.
	2. Poor electrical conditions.	2a. Clean or replace connectors. 2b. Apply dielectric grease.
	3. Electrical short.	3. Check electrical connections.
<b>Turning control knobs does not change motor speed.</b> Control is powered ON.	<b>Unplug the spreader harness and tag out, if required, before performing any of the following repairs.</b>	
	1. Malfunctioning cab control.	1. Replace cab control.
	2. Malfunctioning motor(s).	2. Replace motor(s).
	3. Malfunctioning spreader module.	3. Replace spreader module.
<b>Spreader does not operate.</b>	<b>Unplug the spreader harness and tag out, if required, before performing any of the following repairs.</b>	
	1. Wire harness is damaged or has an open circuit between cab control and spreader.	1a. Check plug connections at cab control and spreader. 1b. Check wire connections at vehicle battery and fuse. 1c. Check motor connections.
	2. Overloaded condition has triggered a time-out, or damaged motors or module.	2a. Wait 60 seconds for time-out to expire. 2b. Check motors. Repair or replace. 2c. Replace module.

89

Table continues on next page.

# TAILGATE SPREADERS: TROUBLESHOOTING GUIDE

Tailgate Spreaders Troubleshooting (continued)

Problem	Possible Cause	Suggested Solution
<b>Motor does not run.</b>	<b>Unplug the spreader harness and tag out, if required, before performing any of the following repairs.</b>	
	1. Electrical connections are loose.	1. Open access cover and check motor, harness, and module connections.
	2. Blown fuse.	2. Replace spreader vehicle battery cable fuse.
	3. Motor seizes.	3. Replace motor.
<b>Material does not flow.</b>	<b>Unplug the spreader harness and tag out, if required, before performing any of the following repairs.</b>	
	1. Obstruction in hopper.	1. Clear obstruction.
	2. Material bridged.	2. Clear the bridged material or adjust the baffle extension.
	3. Auger loose on shaft.	3. Align auger with flat machined area on shaft and tighten locking bolt on side of auger.
	4. Auger runs backward.	4a. Check the wire connections at the "P—FEED—N" posts on the spreader module. Auger harness RED to P—FEED; auger harness BLACK to FEED—N. 4b. Check that auger motor harness is correct part number for spreader model.
	5. Material is wet.	5. Replace with dry material.
	6. Material is coarse or frozen.	6. Replace material.
	7. Spinner does not turn.	7. Check connection inside motor enclosure.
<b>Material free flows.</b>	1. Incorrect baffle length.	1a. Install correct baffle. 1b. Adjust the baffle extension.
	2. Baffle does not touch hopper on three sides.	2. Reposition baffle.
<b>Vibrator does not work.</b>	1. Electrical connections are loose.	1a. Check the vibrator to harness connection. 1b. Check vibrator harness to module connections (BAT, GND, and blue bullet connector).
	2. Blown fuse.	2. Open access cover to replace fuse in the fuse holder on the vibrator harness.
	3. Vibrator failure.	3. Replace vibrator.



# TAILGATE SPREADERS: HARNESS WIRING DIAGRAM

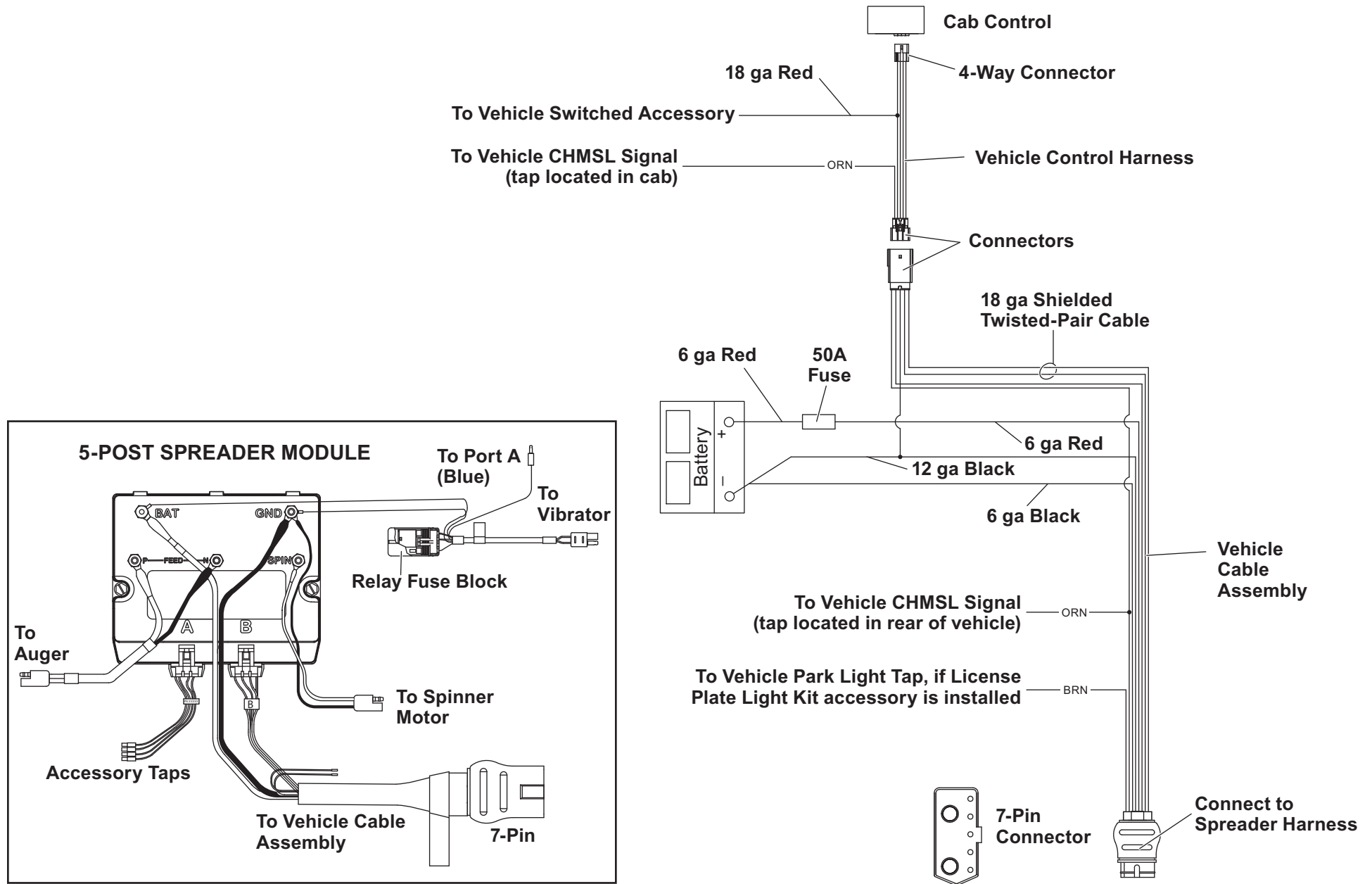

---

---

# **SPEED-CASTER™**

## **Tailgate Spreaders**

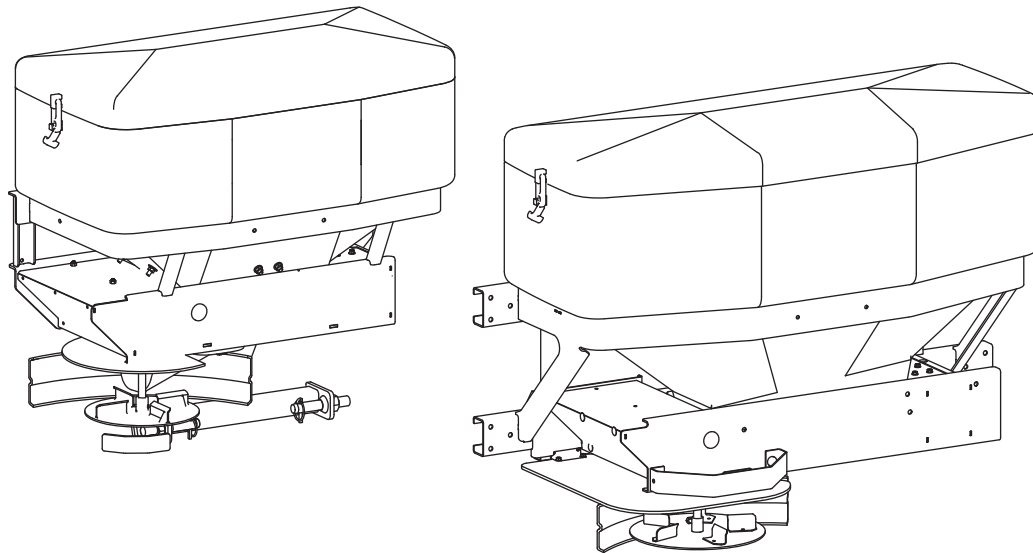

# TAILGATE SPREADERS: SPEED-CASTER™ TAILGATE SPREADERS

---

## HARNESSTESTING

### Tools Needed:

- Multimeter
- Jumper Wire

Before running any electrical tests on the spreader, verify that the vehicle battery and charging system are working correctly. Make sure there are no broken, chafed, or corroded wires. Also, verify that the spreader has no mechanical issues.

Check the routing of the spreader-related vehicle harnesses, making sure they are not run next to any vehicle body control modules, communication lines, or two-way radio power or antenna leads.

When testing harnesses, take care not to cause any damage to the wires, pins, or connectors.

### Checking Vehicle Control Harness

Disconnect the vehicle control harness from the control and the vehicle spreader harness.

1. At the black 6-pin connector, check for continuity between all pins 1–5. **There should NOT be continuity between any combinations of these wires.**
2. Connect the jumper wire between pins 2 and 3 of the white 4-pin connector in the cab. Connect the meter between pins 2 and 3 of the black 6-pin connector. The meter should read continuity.

---

**NOTE: If the harness fails any of the above tests, replace the harness.**

---

3. With the meter ground lead connected to a vehicle ground, turn the key ON and check for 12V on pin 4 at the black 6-pin connector. Then check for battery voltage on pin 1 of the white 4-pin connector in the cab.

---

**NOTE: If battery voltage is missing, repair or replace the harness, as needed.**

---

4. Check for continuity between pin 1 at the black 6-pin connector and pin 4 of the white 4-pin connector in the cab.
5. If applicable: If the orange CHMSL wire is connected to the brake lighting circuit in the cab of the vehicle, depress the brake pedal and check for 12V on the black 6-pin connector at pin 4.

---

**NOTE: Not all vehicles will connect in the cab. Some may need to be connected at the rear of the vehicle. Check the body builder's guide pertaining to the make of your vehicle.**

---

# TAILGATE SPREADERS: SPEED-CASTER™ TAILGATE SPREADERS

## TAILGATE HARNESS/CABLE

Location: Near Vehicle  
Battery Connections

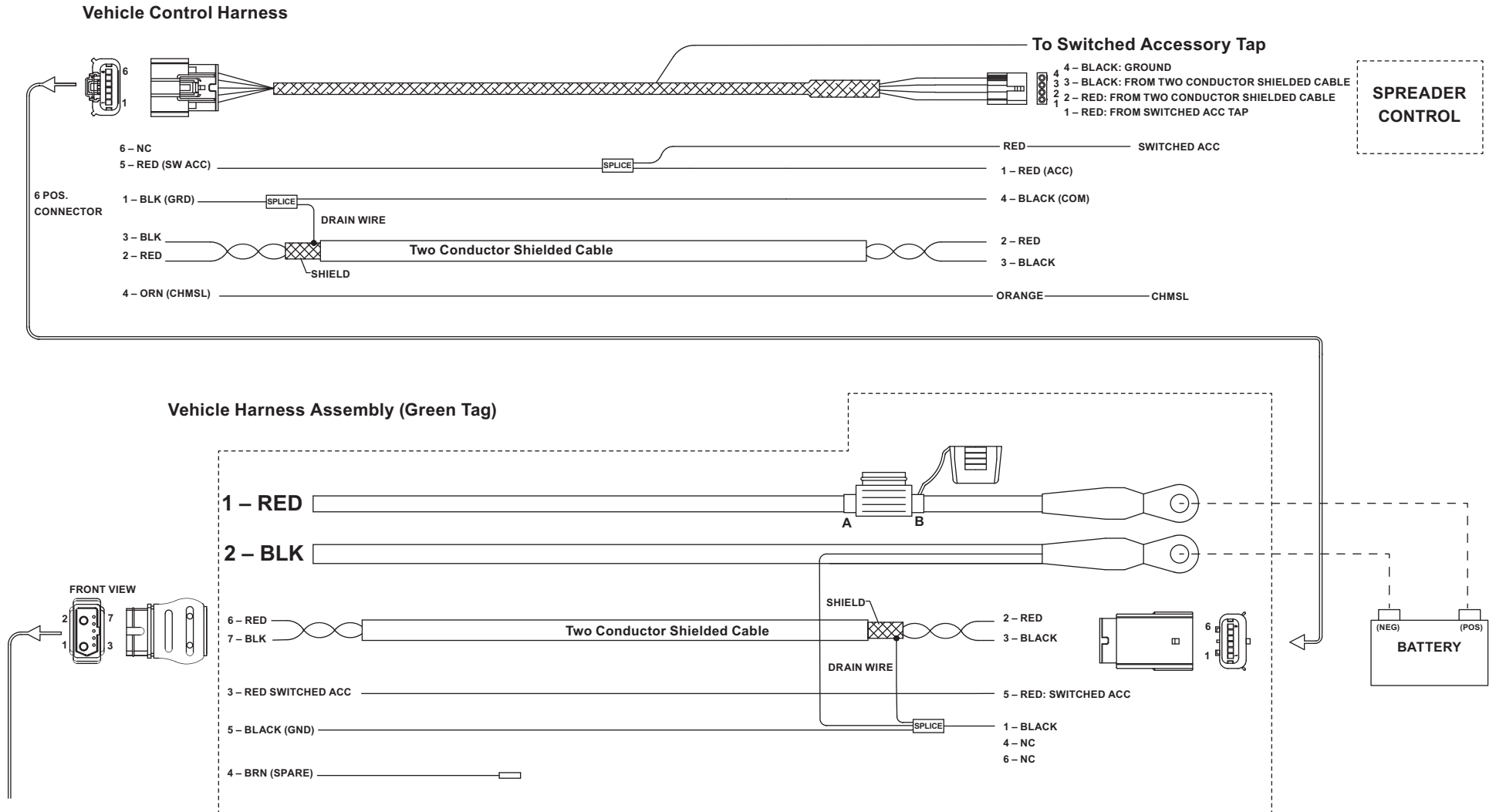

# TAILGATE SPREADERS: SPEED-CASTER™ TAILGATE SPREADERS

## TAILGATE HARNESS/CABLE

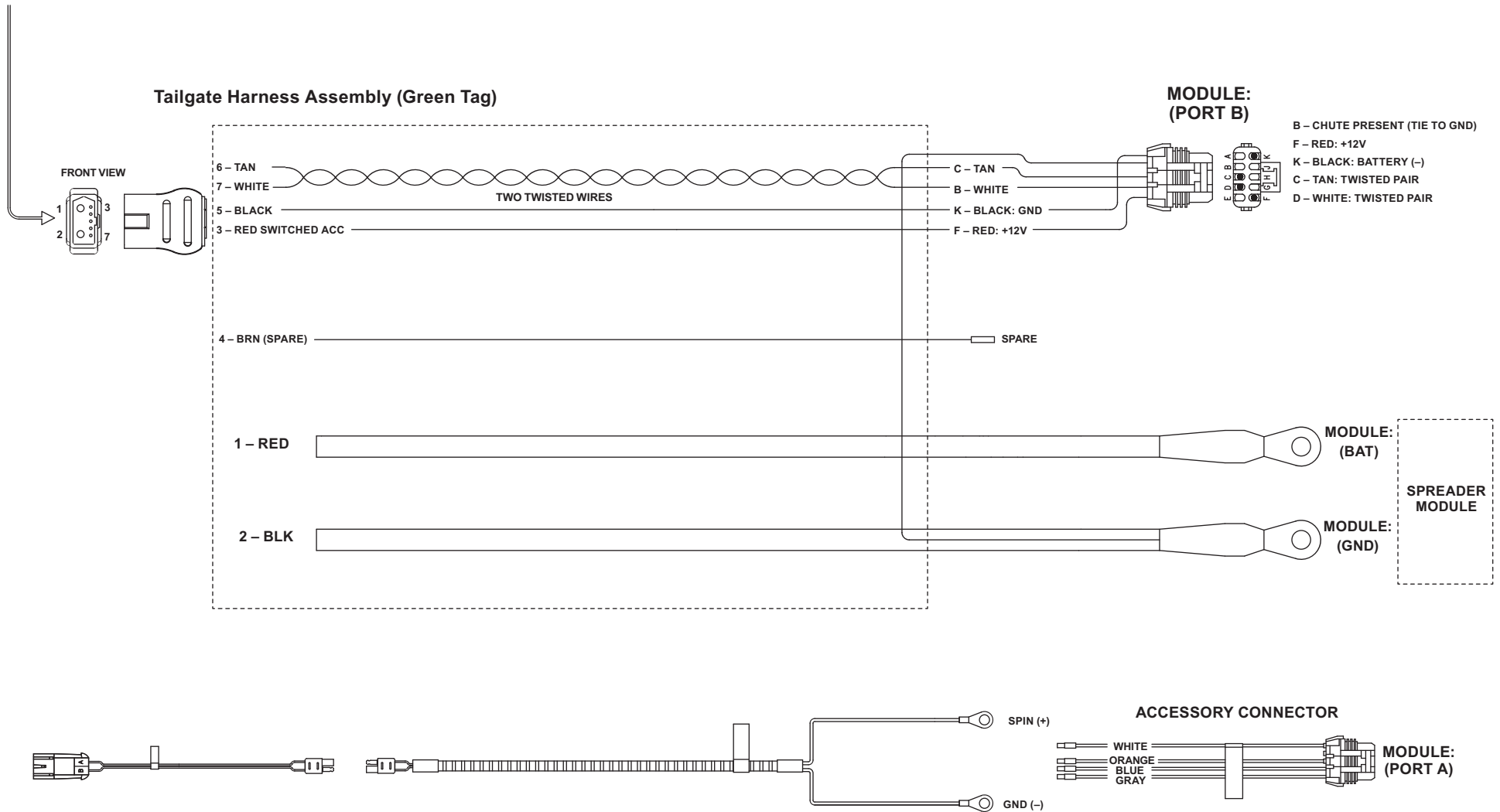

## TAILGATE SPREADERS: SPEED-CASTER™ TAILGATE SPREADERS

---

### Checking Vehicle Spreader Harness

1. Disconnect the vehicle spreader harness from the vehicle control harness at the black 6-pin connector, and disconnect the vehicle spreader harness from the 7-pin spreader harness at the rear of the vehicle. Leave the POSITIVE (+) and NEGATIVE (-) battery connections connected to the battery.
2. At the 7-pin connector, check for continuity between all pins 3–7. **There should NOT be any continuity between any of these wires.**
3. Connect the jumper wire between pins 2 and 3 of the black 6-pin connector. Connect the meter between pins 6 and 7 of the black 7-pin plug. The meter should read zero continuity.

---

**NOTE: If the harness fails any of the above tests, replace the harness.**

---

4. With a meter, check for battery voltage at pins 1 and 2 of the 7-pin plug. If voltage is low, or if no power exists, check for loose or corroded connections at the vehicle battery and at the 50A fuse.

5. With the positive (red) lead of the meter connected to pin 1 of the ground (black) 7-pin plug, take the black lead and check pin 5 of this plug for ground. Also check pin 1 of the black 6-pin connector for ground.
6. Connect the jumper wire between pins 1 and 3 of the 7-pin plug. At the black 6-pin connector, check for battery voltage. Use the red lead of the tester on pin 5 and black tester lead on pin 1.
7. To check the license plate light (if installed) turn on the parking lights and check for battery voltage at pin 4.

### Checking Spreader Harness Assembly

1. Disconnect the spreader harness from the vehicle spreader harness and from port B of the spreader module.
2. Visually inspect the wiring harness for damage.
3. At the 7-pin connector, check for continuity between all pins 3–7. **There should NOT be any trace of continuity between any combinations of these wires.**
4. Check the switched accessory wire for continuity from pin 3 at the 7-pin plug to pin F at the 10-pin connector.
5. Check the battery ground wire for continuity from pin 5 at the 7-pin plug to pin K at the 10-pin connector. Also check between pin 2 and pin K.
6. Check the plate light wire for continuity from pin 4 to the 7-pin plug to the brown wire at the plate light.
7. Connect the jumper wire between pins B and C of the black 10-pin connector. Connect the meter between pins 6 and 7 of the black 7-pin plug. The meter should read zero resistance.

---

**NOTE: If the harness fails any of the above tests, replace the harness.**

---

---

# **LOW-PROFILE Tailgate Spreaders**

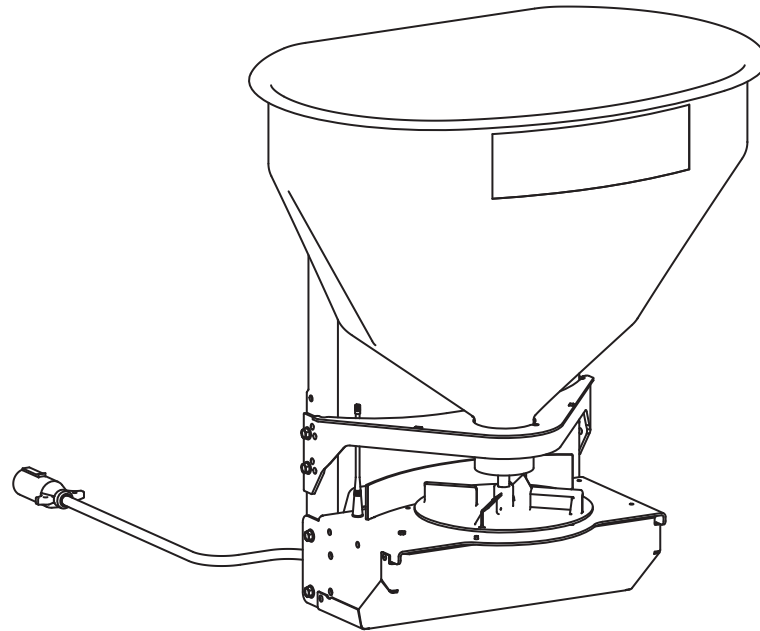

# TAILGATE SPREADERS: LOW PROFILE

## LOW PROFILE TAILGATE SPREADER

### Checking Wireless Control for Output

Verify that the control battery is good:

- CR2032: 3V
- If voltage is below 2.7V: Replace battery.

### Amperage Draw

- 3.5A: Empty
- 10A: Loaded

## WIRELESS CONTROL PROGRAMMING AND PAIRING

### When to program and pair the wireless key fob control:

The wireless key fob control included with the spreader should come paired and ready for use.

If the spreader does not respond to the wireless key fob control, or after replacing the battery (CR2032 battery or equivalent), you will need to program the wireless key fob control and pair it to the spreader's wireless control module.

### Ensuring the spreader has power

**The spreader is only compatible with 7-way RV-style trailer plugs. If your vehicle is not equipped with a 7-way trailer plug, contact Customer Support to purchase the necessary electrical harness.**

1. The spreader must be receiving power from the vehicle to pair and program the wireless key fob control. Begin by unplugging the spreader from the 7-way plug.
2. Push the toggle switch DOWN into the "MANUAL OVERRIDE" position.

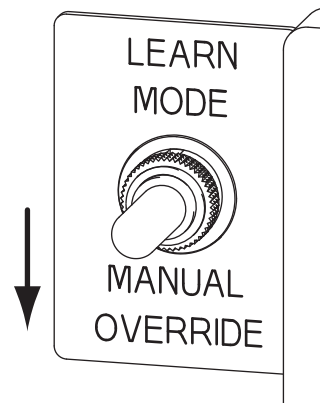

**⚠ WARNING**  
**The spinner will start immediately upon connecting power while in manual override mode. Keep hands and tools clear of spinner assembly.**

3. Plug the spreader into the 7-way plug. Be sure to check that the plug polarity is correct, as shown below. The spreader will start at 100% speed.

### Spreader Power Plug End View

**Battery Power POSITIVE (+)  
Black Wire**

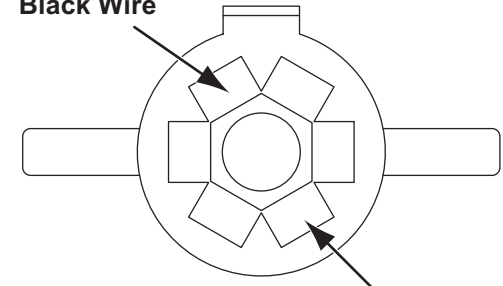

**Battery Ground NEGATIVE (-)  
White Wire**

4. Unplug the spreader, push the toggle switch into the center position, and then reconnect power to the spreader.

The spreader must be unplugged after running an override. The wireless key fob control will remain locked out until power is removed from the spreader unit.

5. If power is not present, consult the trailering section in the vehicle owner's manual for more information.



# TAILGATE SPREADERS: LOW PROFILE

## PROGRAMMING AND PAIRING THE WIRELESS KEY FOB CONTROL

### Resetting the Wireless Control Module

Push and hold the toggle switch UP into the "LEARN MODE" position for 15 seconds and then release. This erases all previously paired wireless key fob controls from memory. A wireless key fob control must be paired before the spreader will operate.

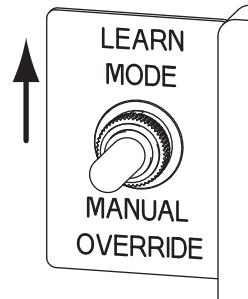

### Programming the Wireless Key Fob Control

1. Gently press the end of a pointed object (e.g., ballpoint pen) into the small hole on the underside of the wireless key fob control. A blue light on the underside of the key fob will flash for 10–15 seconds, indicating that the wireless key fob control will accept programming.



2. While the blue light is flashing, press the wireless key fob control buttons in the following sequence:

**50%, OFF, 100%, 50%, OFF, 100%**

The sequence must be completed before the blue light stops flashing.

### Pairing the Wireless Key Fob Control to the Wireless Control Module

1. Check that the wireless control module is receiving a signal by confirming that a red light is visible through the bottommost hole in the toggle switch side of the transmission mount.

#### **⚠ WARNING**

**The spinner will start immediately upon connecting power while in manual override mode. Keep hands and tools clear of spinner assembly.**

2. Press and hold the "50%" button on the wireless key fob control. While holding the button, push the toggle switch UP into the "LEARN MODE" position twice and release the toggle switch. Continue holding the button for 30 seconds and the spreader will start at 50% speed.

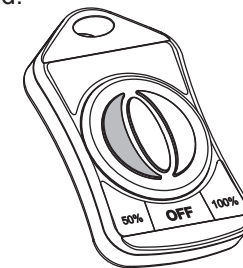

If the spreader does not start, release the "50%" button, wait 20 seconds and then repeat Step 2.

3. Press the "100%" button to make sure the spreader runs at 100% speed.

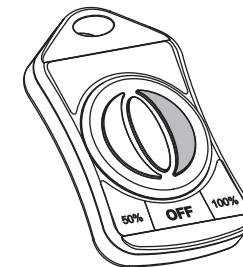

If any of the buttons are not working, return to "Resetting the Wireless Control Module," and repeat the entire programming and pairing process.

# TAILGATE SPREADERS: LOW PROFILE

---

## WIRELESS COMPLIANCE

This device complies with Part 15 of the FCC Rules.

Operation of this device is subject to the following two conditions:

- (1) This device may not cause harmful interference, and
- (2) This device must accept any interference received, including interference that may cause undesired operation.

This equipment has been tested and found to comply with the limits for a Class B digital device, pursuant to Part 15 of the FCC Rules. These limits are designed to provide reasonable protection against harmful interference in a residential installation. This equipment generates, uses, and can radiate radio frequency energy and, if not installed and used in accordance with the instructions, may cause harmful interference to radio communications. However, there is no guarantee that interference will not occur in a particular installation.

If this equipment does cause harmful interference to radio or television reception, which can be determined by turning the equipment OFF and ON, the user is encouraged to try to correct the interference by one or more of the following measures:

- Reorient or relocate the receiving antenna.
- Increase the separation between the equipment and receiver.
- Connect the equipment into an outlet on a circuit different from that to which the receiver is connected.
- Consult the dealer or an experienced radio/TV technician for help.

100

This equipment has been certified to comply with the limits for a Class B computing device, pursuant to FCC Rules. In order to maintain compliance with FCC regulations, shielded cables must be used with this equipment. Operation with non-approved equipment or unshielded cables is likely to result in interference to radio or TV reception. The user is cautioned that changes and modifications made to the equipment without the approval of the manufacturer could void the user's authority to operate this equipment.

The actual size labels below must be located on the spreader to comply with FCC Rules.

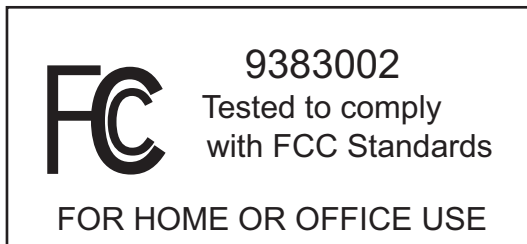

This device complies with Part 15 of the FCC Rules. Operation is subject to the condition that this device does not cause harmful interference.

# TAILGATE SPREADERS: LOW PROFILE

## ELECTRICAL DIAGRAM – WIRELESS RECEIVER MODULE CONNECTIONS

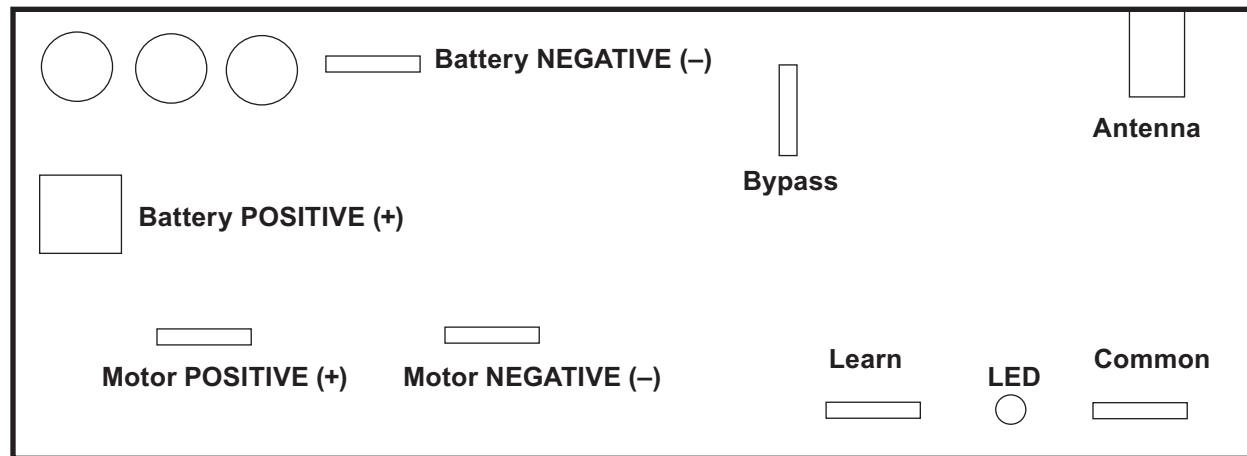

Wireless Receiver Module Connections

# TAILGATE SPREADERS: LOW PROFILE

## 7-PIN, 7-WAY ACCESSORY HARNESS, 216"

**NOTES:**  
Pos. #1 – White (GRD)  
Pos. #4 – Black (BATT [+])  
All Others Blank

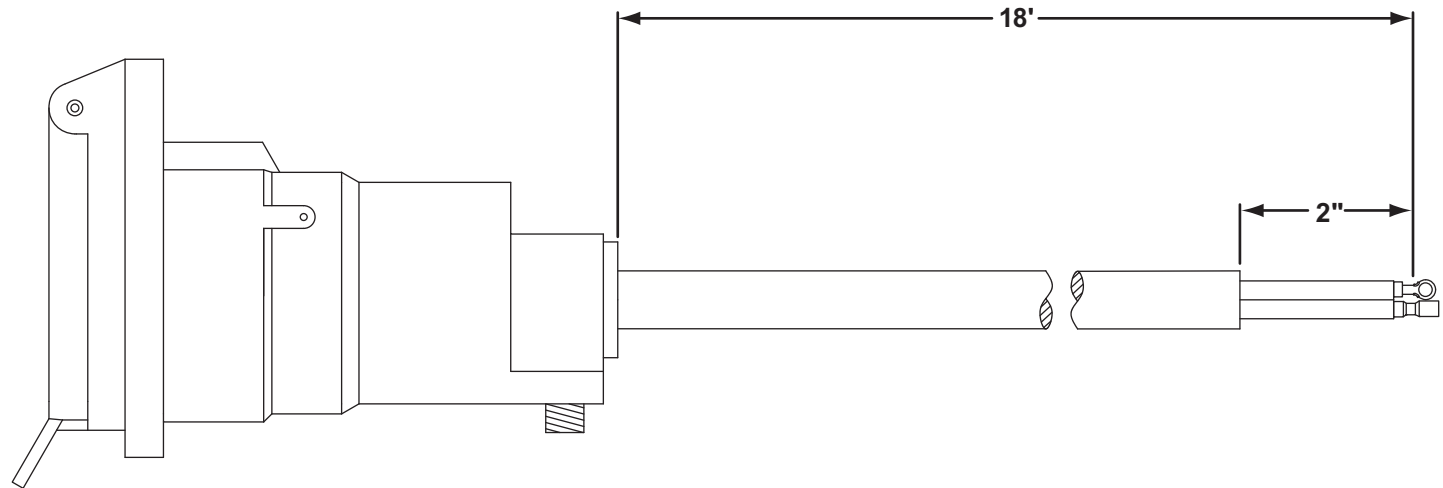

102

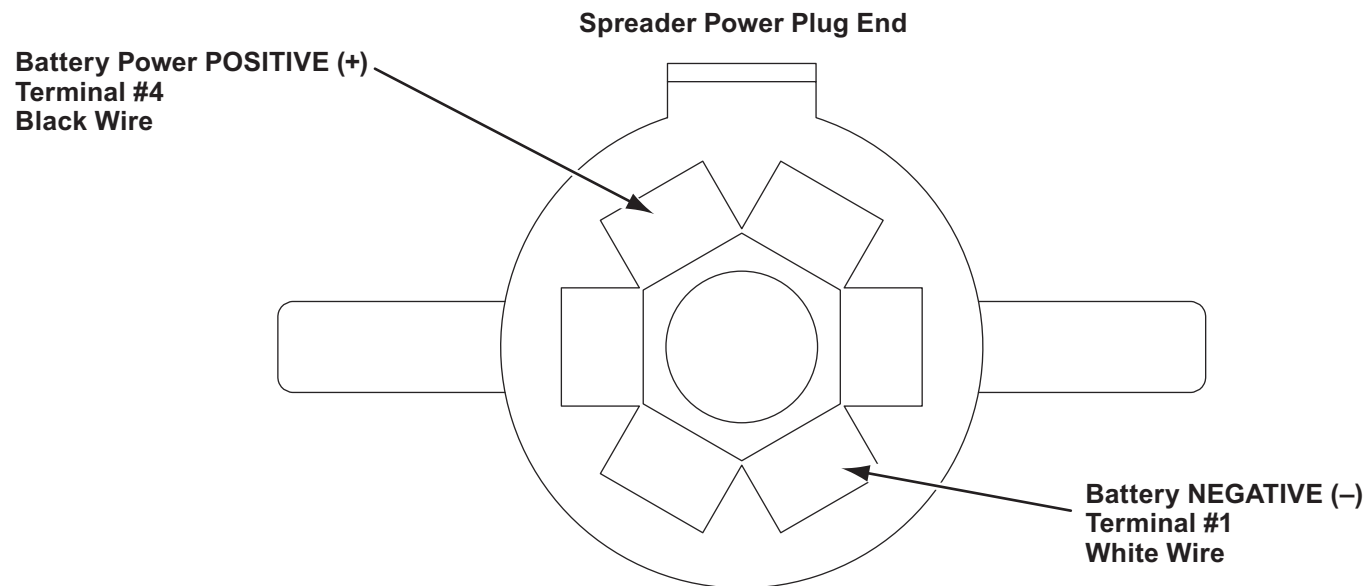

# TAILGATE SPREADERS: LOW PROFILE

## TROUBLESHOOTING

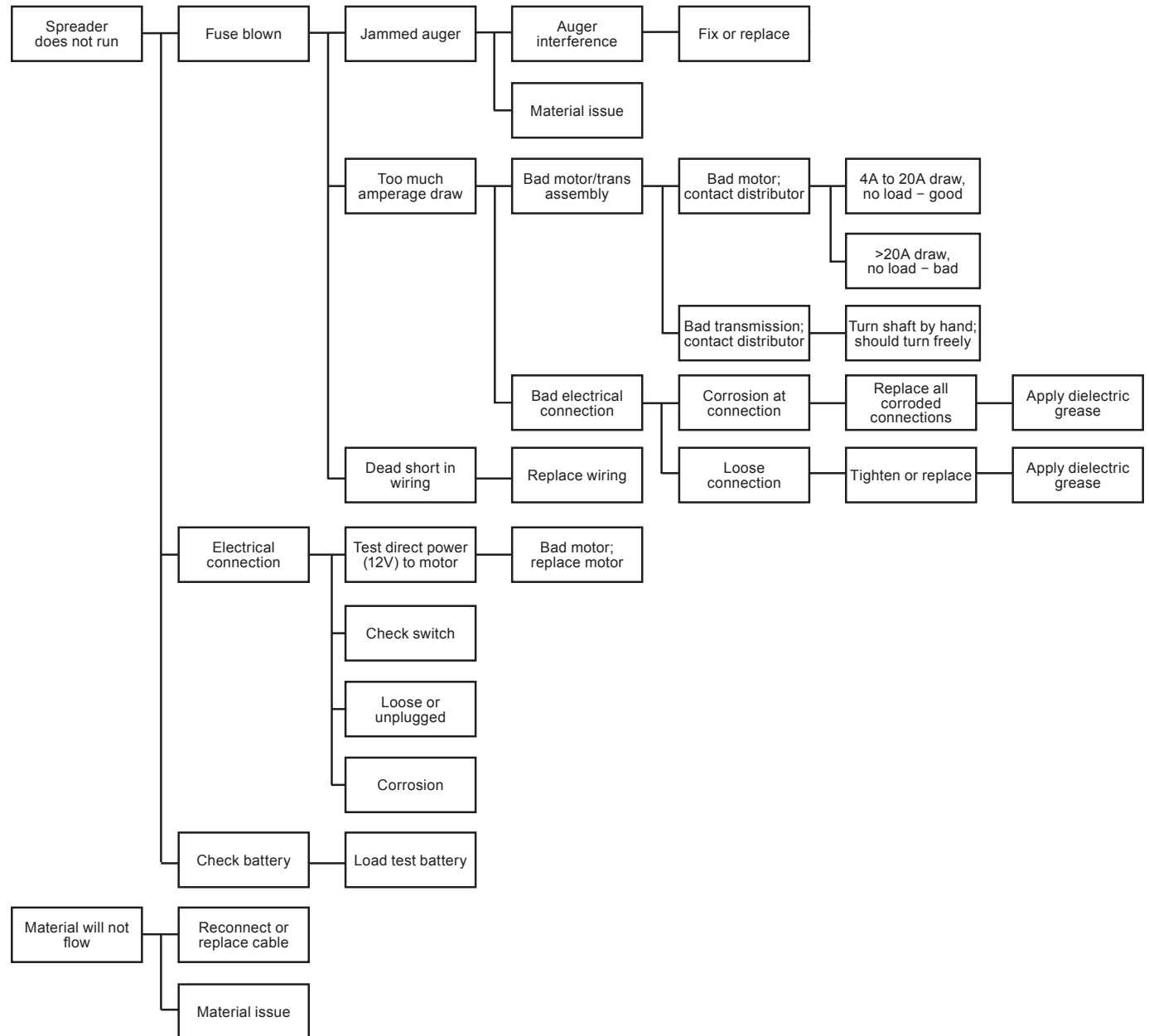



Fisher Engineering  
50 Gordon Drive  
Rockland, ME 04841-2139  
[www.fisherplows.com](http://www.fisherplows.com)

**dd** A DIVISION OF FISHER, LLC

Copyright © 2018 Douglas Dynamics, LLC. All rights reserved. This material may not be reproduced or copied, in whole or in part, in any printed, mechanical, electronic, film, or other distribution and storage media, without the written consent of Fisher Engineering. Authorization to photocopy items for internal or personal use by Fisher Engineering outlets or spreader owner is granted.

Fisher Engineering reserves the right under its product improvement policy to change construction or design details and furnish equipment when so altered without reference to illustrations or specifications used. Fisher Engineering or the vehicle manufacturer may require or recommend optional equipment for snow removal. Do not exceed vehicle ratings with a spreader. Fisher Engineering offers a limited warranty for all spreaders and accessories. See separately printed page for this important information. The following are registered (®) or unregistered (™) trademarks of Douglas Dynamics, LLC: FISHER®, POLY-CASTER™, SPEED-CASTER™, STEEL-CASTER™.

**Printed in U.S.A.**